

YASKAWA

GA500

Industrial AC Microdrive Selection Guide

Catalog Code: GA50Uxxxxxxx

240 V: Single - Phase, 1/6 to 5 HP
240 V: Three - Phase, 1/6 to 30 HP
480 V: Three - Phase, 1/2 to 40 HP

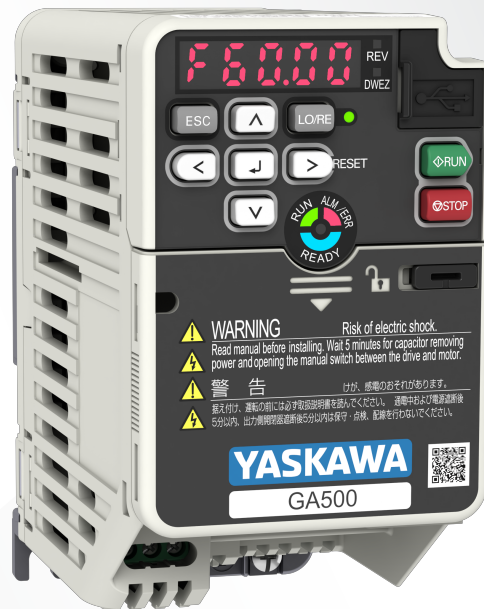
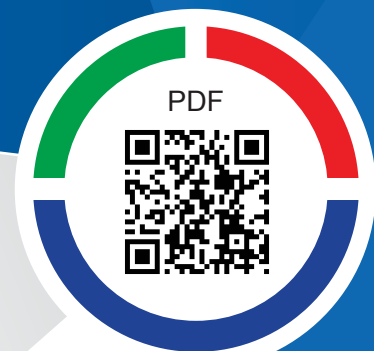

Copyright © 2021 YASKAWA AMERICA, INC.

All rights reserved. No part of this publication may be reproduced, stored in a retrieval system, or transmitted, in any form or by any means, mechanical, electronic, photocopying, recording, or otherwise, without the prior written permission of Yaskawa. No patent liability is assumed with respect to the use of the information contained herein. Moreover, because Yaskawa is constantly striving to improve its high-quality products, the information contained in this manual is subject to change without notice. Every precaution has been taken in the preparation of this manual. Yaskawa assumes no responsibility for errors or omissions. Neither is any liability assumed for damages resulting from the use of the information contained in this publication.

Table of Contents

Preface	2
Additional Resources	2
GA500 AC Microdrives	3
Drive Selection	3
GA500 Drive Variants	6
Single-Phase Input Drive Derate	8
Dimensions & Weights	10
IP20/Protected Chassis Dimensions	10
Finless Drive Chassis Dimensions	12
Drive Specifications	14
Network Communication Options	15
Keypad and Accessories	16
Enclosure Adapters and Kits	19
IP20/UL Type 1 Adapters	19
External Heatsink Adapters	22
DIN Rail Mounting Adapters	24
Power Options	25
EMC Filters	26
EMC Filter Dimensions	28
DC Bus Reactors	29
AC Input Reactors	33
AC Output Reactors	36
AC Open Reactor Dimensions	39
Enclosed AC Reactor Dimensions	41
Dynamic Braking Options	44
10% Dynamic Braking Options	44
3% Dynamic Braking Options	47
R1000 Regenerative Systems	49
R1000 External Heatsink Kits	52
Single Phase Converter	53
GA500 Drive Derating	55
Carrier Frequency	55
Altitude	58
Ambient Temperature	58
Watt Loss	59
Watt Loss without EMC Filter	59
Watt Loss with EMC Filter	61
Branch Circuit Protection	63

Preface

This book is intended to help easily locate component information for Yaskawa GA500 Drives and optional accessories.

The intended users for this document are Yaskawa sales personnel, distributors, and partners.

This book may describe trademarked equipment, which is the property of other companies. These trademarks are the property of the registered owner companies and may include the following:

DeviceNet™, trademark of ODVA

Modbus®, trademark of Schneider Automation, Inc.

EtherCAT, trademark of Beckhoff Automation GmbH, Germany

MECHATROLINK - I, II, III, trademarks of MECHATROLINK Members Association

PROFIBUS®, trademark of PROFIBUS International.

PROFINET®, trademark of PROFIBUS International.

Ethernet/IP, trademark of ODVA

Bluetooth® word mark and logos are registered trademarks owned by Bluetooth SIG, Inc.

Other Documents and Manuals are available to support special use or installation of this product. These documents may be provided with the product or upon request. Contact Yaskawa America, Inc. or visit www.yaskawa.com.

Additional Resources

The Yaskawa.com web site has the most current information for all Yaskawa products. When researching product specifications or features the Yaskawa web site is the best resource to use. Some useful links for the GA500 drive product are listed here and throughout this document:

Resource Links	
GA500 Price Book	GA500 Flyer
GA500 Brochure	GA500 Product Transition Guide



GA500 AC Microdrives



Drive Selection

The GA500 precisely controls induction, permanent magnet, and synchronous reluctance motors providing versatility to run a variety of applications with just one drive. The times of complex motor setup are over. With the new EZ Vector mode, the GA500 can run all of these motor types without comprehensive tuning.

- Time and Cost Savings
- Easy Installation and System Integration
- Easy to Use - Easy to Maintain
- More Reliable - Easier Machine Design

Standard (IP20/Protected Chassis) drives are intended for clean environments and can be mounted 3 different ways as follows:

- 1) In a separate enclosure with heatsink internal. Extra mounting brackets are not required.
- 2) In a separate enclosure with heatsink external. Refer to Enclosure Adapters and Kits for drives requiring extra mounting brackets.
- 3) Mounted without an enclosure. UL Type 1 Adapters must be used when mounting the drive without an enclosure.

The GA500 offers two separate performance ratings; Heavy Duty and Normal Duty. Heavy Duty is capable of creating more powerful torque, while Normal Duty allows the drive to operate a larger motor.

Catalog Code Designation

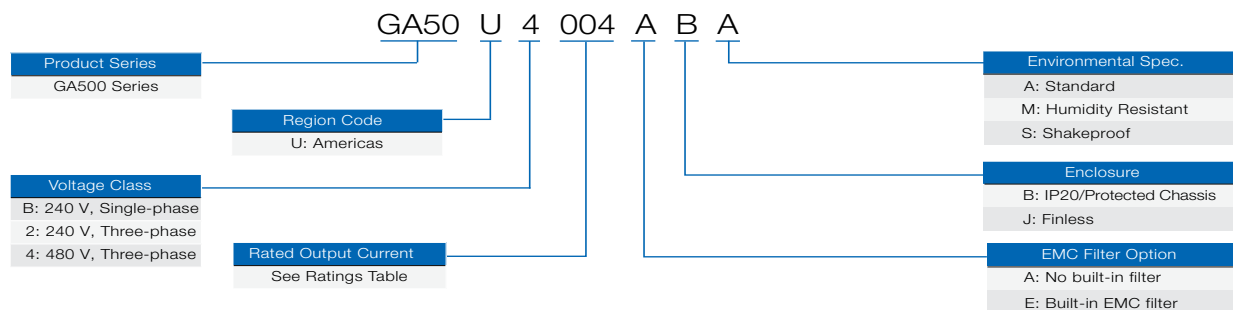

Table 1: 240 V, Single-Phase Input, IP20/Protected Chassis Drives, 1/6 to 5 HP

Normal Duty Output		Heavy Duty Output		Standard Drives ¹	Built-In EMC Drives ²
HP	Amps	HP	Amps	Catalog Code GA50U...	Catalog Code GA50U...
1/6	1.2	1/6	0.8	B001ABA	B001EBA
1/4	1.9	1/4	1.6	B002ABA	B002EBA
3/4	3.5	1/2	3	B004ABA	B004EBA
1.5	6	1	5	B006ABA	B006EBA
3	9.6	2	8	B010ABA	B010EBA
3	12.2	3	11	B012ABA	B012EBA
N/A	N/A	5	17.6	B018ABA	N/A

- Standard (IP20/Protected Chassis) Drives are intended for clean environments, and can be mounted 3 different ways as follows:
 - In a separate enclosure with heatsink internal (no extra mounting brackets required)
 - In a separate enclosure with heatsink external. See External Heatsink Adapters for sizes requiring extra mounting brackets
 - Without a separate enclosure, all sizes require UL Type 1 Adapters (see UL Type 1 Adapters)
- E: Built-in EMC Filter: C1: 200 V Single-Phase, C3: 200 V Three-Phase, C2: 400 V Three-Phase

Table 2: 240 V, Three-Phase Input, IP20/Protected Chassis Drives, 1/6 to 30 HP

Normal Duty Output		Heavy Duty Output		Standard Drives ¹	Built-In EMC Drives ²
HP	Amps	HP	Amps	Catalog Code GA50U...	Catalog Code GA50U...
1/6	1.2	1/6	0.8	2001ABA	2001EBA
1/4	1.9	1/4	1.6	2002ABA	2002EBA
3/4	3.5	1/2	3	2004ABA	2004EBA
1.5	6	1	5	2006ABA	2006EBA
3	9.6	2	8	2010ABA	2010EBA
4	12.2	3	11	2012ABA	2012EBA
7.5	21	5	17	2021ABA	2021EBA
10	30	7.5	25	2030ABA	2030EBA
15	42	10	33	2042ABA	2042EBA
20	56	15	47	2056ABA	2056EBA
25	70	20	60	2070ABA	2070EBA
30	82	25	75	2082ABA	2082EBA

- Standard (IP20/Protected Chassis) Drives are intended for clean environments, and can be mounted 3 different ways as follows:
 - In a separate enclosure with heatsink internal (no extra mounting brackets required)
 - In a separate enclosure with heatsink external. See External Heatsink Adapters for sizes requiring extra mounting brackets
 - Without a separate enclosure, all sizes require UL Type 1 Adapters (see UL Type 1 Adapters)
- E: Built-in EMC Filter: C1: 200 V Single-Phase, C3: 200 V Three-Phase, C2: 400 V Three-Phase

Table 3: 480 V, Three-Phase Input, IP20/Protected Chassis Drive, 1 to 40 HP

Normal Duty Output		Heavy Duty Output ¹		Standard Drives ²	Built-In EMC Drives ³
HP	Amps	HP	Amps	Catalog Code GA50U...	Catalog Code GA50U...
1/2	1.2	1/2	1.2	4001ABA	4001EBA
1	2.1	3/4	1.8	4002ABA	4002EBA
2	4.1	2	3.4	4004ABA	4004EBA
3	5.4	3	4.8	4005ABA	4005EBA
4	7.1	3	5.6	4007ABA	4007EBA
5	8.9	4	7.3	4009ABA	4009EBA
7.5	11.9	5	9.2	4012ABA	4012EBA
10	17.5	10	14.8	4018ABA	4018EBA
15	23.4	10	18	4023ABA	4023EBA
20	31	15	24	4031ABA	4031EBA
25	38	20	31	4038ABA	4038EBA
30	44	25	39	4044ABA	4044EBA
40	60	30	45	4060ABA	4060EBA

- Output capacities stated are for conditions of 3 phase input, DC input, and 12 pulse input. See Single Phase Input Drive Selection for single phase capability.
- Standard (IP20/Protected Chassis) Drives are intended for clean environments, and can be mounted 3 different ways as follows:
 - In a separate enclosure with heatsink internal (no extra mounting brackets required)
 - In a separate enclosure with heatsink external. See External Heatsink Adapters for sizes requiring extra mounting brackets
 - Without a separate enclosure, all sizes require UL Type 1 Adapters (see UL Type 1 Adapters)
- E: Built-in EMC Filter: C1: 200 V Single-Phase, C3: 200 V Three-Phase, C2: 400 V Three-Phase

GA500 Drive Variants

GA500 drive variants provide enhanced or alternate capabilities to that of the standard GA500 drive. All GA500 drive variants, with the exception of the High Frequency Output, are subject to a 16 week lead time if no forecast is provided.

Table 4: 240 V, Single-Phase Input Drive Selection

Normal Duty Output ¹		Heavy Duty Output ¹		High Frequency Output (2000 Hz)	Shakeproof	Humidity Resistance	Humidity Resistance (w/EMC Filter)	Finless
HP	Amps	HP	Amps	Catalog Code	Catalog Code	Catalog Code	Catalog Code	Catalog Code
1/6	1.2	1/6	0.8	GA50UB001ABA-134	GA50UB001ABS	GA50UB001ABM	GA50UB001EBM	GA50UB001AJA
1/4	1.9	1/4	1.6	GA50UB002ABA-134	GA50UB002ABS	GA50UB002ABM	GA50UB002EBM	GA50UB002AJA
3/4	3.3	1/2	3	GA50UB004ABA-134	GA50UB004ABS	GA50UB004ABM	GA50UB004EBM	GA50UB004AJA
1.5	6	1	5	GA50UB006ABA-134	GA50UB006ABS	GA50UB006ABM	GA50UB006EBM	GA50UB006AJA
3	9.6	2	8	GA50UB010ABA-134	GA50UB010ABS	GA50UB010ABM	GA50UB010EBM	GA50UB010AJA
3	12	3	11	GA50UB012ABA-134	GA50UB012ABS	GA50UB012ABM	GA50UB012EBM	GA50UB012AJA
N/A	N/A	5	17.5	GA50UB018ABA-134	GA50UB018ABS	GA50UB018ABM	N/A	NA

1. Output capacities stated are for conditions of single-phase input or DC input.

Table 5: 240 V, Three-Phase Input Drive Selection

Normal Duty Output ¹		Heavy Duty Output ¹		High Frequency Output (2000 Hz)	Shakeproof	Humidity Resistance	Humidity Resistance (w/EMC Filter)	Finless
HP	Amps	HP	Amps	Catalog Code	Catalog Code	Catalog Code	Catalog Code	Catalog Code
1/6	1.2	1/6	0.8	GA50U2001ABA-134	GA50U2001ABS	GA50U2001ABM	GA50U2001EBM	GA50U2001AJA
1/4	1.9	1/4	1.6	GA50U2002ABA-134	GA50U2002ABS	GA50U2002ABM	GA50U2002EBM	GA50U2002AJA
3/4	3.5	1/2	3	GA50U2004ABA-134	GA50U2004ABS	GA50U2004ABM	GA50U2004EBM	GA50U2004AJA
1.5	6	1	5	GA50U2006ABA-134	GA50U2006ABS	GA50U2006ABM	GA50U2006EBM	GA50U2006AJA
3	9.6	2	8	GA50U2010ABA-134	GA50U2010ABS	GA50U2010ABM	GA50U2010EBM	GA50U2010AJA
4	12.2	3	11	GA50U2012ABA-134	GA50U2012ABS	GA50U2012ABM	GA50U2012EBM	GA50U2012AJA
7.5	21	5	17.6	GA50U2021ABA-134	GA50U2021ABS	GA50U2021ABM	GA50U2021EBM	GA50U2021AJA
10	30	7.5	25	GA50U2030ABA-134	GA50U2030ABS	GA50U2030ABM	GA50U2030EBM	Contact Factory
15	42	10	33	GA50U2042ABA-134	GA50U2042ABS	GA50U2042ABM	GA50U2042EBM	
20	56	15	47	GA50U2056ABA-134	GA50U2056ABS	GA50U2056ABM	GA50U2056EBM	
25	70	20	60	GA50U2070ABA-134	GA50U2070ABS	GA50U2070ABM	GA50U2070EBM	
30	82	25	75	GA50U2082ABA-134	GA50U2082ABS	GA50U2082ABM	GA50U2082EBM	NA

1. Output capacities stated are for conditions of 3 phase input or DC input. See Single-Phase Input Drive Selection for single phase capability.

Table 6: 480 V, Three-Phase Input Drive Selection

Normal Duty Output ¹		Heavy Duty Output ¹		High Frequency Output (2000 Hz)	Shakeproof	Humidity Resistance	Humidity Resistance (w/EMC Filter)	Finless
HP	Amps	HP	Amps	Catalog Code	Catalog Code	Catalog Code	Catalog Code	Catalog Code
0.5	1.2	0.5	1.2	GA50U4001ABA-134	GA50U4001ABS	GA50U4001ABM	GA50U4001EBM	GA50U4001AJA
1	2.1	0.75	1.8	GA50U4002ABA-134	GA50U4002ABS	GA50U4002ABM	GA50U4002EBM	GA50U4002AJA
2	4.1	2	3.4	GA50U4004ABA-134	GA50U4004ABS	GA50U4004ABM	GA50U4004EBM	GA50U4004AJA
3	5.4	3	4.8	GA50U4005ABA-134	GA50U4005ABS	GA50U4005ABM	GA50U4005EBM	GA50U4005AJA
4	7.1	3	5.6	GA50U4007ABA-134	GA50U4007ABS	GA50U4007ABM	GA50U4007EBM	GA50U4007AJA
5	8.9	4	7.3	GA50U4009ABA-134	GA50U4009ABS	GA50U4009ABM	GA50U4009EBM	GA50U4009AJA
7.5	11.9	5	9.2	GA50U4012ABA-134	GA50U4012ABS	GA50U4012ABM	GA50U4012EBM	GA50U4012AJA
10	17.5	10	14.8	GA50U4018ABA-134	GA50U4018ABS	GA50U4018ABM	GA50U4018EBM	Contact Factory
15	23.4	10	18	GA50U4023ABA-134	GA50U4023ABS	GA50U4023ABM	GA50U4023EBM	
20	31	15	24	GA50U4031ABA-134	GA50U4031ABS	GA50U4031ABM	GA50U4031EBM	
25	38	20	31	GA50U4038ABA-134	GA50U4038ABS	GA50U4038ABM	GA50U4038EBM	
30	44	25	39	GA50U4044ABA-134	GA50U4044ABS	GA50U4044ABM	GA50U4044EBM	NA
40	60	30	45	GA50U4060ABA-134	GA50U4060ABS	GA50U4060ABM	GA50U4060EBM	NA

1. Output capacities stated are for conditions of 3 phase input or DC input. See Single-Phase Input Drive Selection for single phase capability.

Single-Phase Input Drive Derate

Table 7: 240 V, Single-Phase Input, Three-Phase Output

GA50U.. ^{1,2}	No Reactor		With Reactor					
	Drive Output Capacity		Drive Output Capacity		AC Input Type		DC Bus Type	
	Motor Power (HP)	Motor FLA	Motor Power (HP)	Motor FLA	Open	UL Type 1 Enclosed	Open	UL Type 1 Enclosed
					Catalog Code	Catalog Code	Catalog Code	Catalog Code
2001	-	-	1/8	0.61	URX000283	URX000652	URX000033	URX000215
2002	1/8	0.61	1/4	1.16	URX000291	URX000651	URX000036	URX000207
2004	1/4	1.16	1/3	1.52	URX000295	URX000409	05P00608-3007	URX000208
2006	1/3	1.52	1/2	2.20	URX000299	URX000410	05P00608-3007	URX000208
2010	1/2	2.2	1	4.20	URX000303	URX000411	URX000043	N/A
2012	1	4.2	1.5	6.00	URX000307	URX000413	05P00620-0113	URX000435
2021	1.5	6	3	9.60	URX000315	URX000418	05P00620-0115	URX000259
2030	1.5	6	3	9.60	URX000315	URX000418	05P00620-0115	URX000259
2042	3	9.6	5	15.20	URX000323	URX000422	05P00620-0120	URX000261
2056	3	9.6	5	15.20	URX000323	URX000422	05P00620-0120	URX000261
2070	5	15.2	10	28.00	URX000329	URX000501	URX000064	URX000213
2082	7.5	22	10	28.00	URX000329	URX000501	URX000063	URX000264

1. This information reflects derating of three phase drives for single-phase input applications. See Single-Phase Converter to achieve full power with no derating on some drives.
2. Select partial catalog code from this single-phase table. Then get complete catalog code and list price from the Drive tables based on drive type in the GA500 Price Book.

Table 8: 480 V, Single-Phase Input, Three-Phase Output

GA50U.. ^{1,2}	No Reactor		With Reactor					
	Drive Output Capacity		Drive Output Capacity		AC Input Type		DC Bus Type	
					Open	UL Type 1 Enclosed	Open	UL Type 1 Enclosed
	Motor Power (HP)	Motor FLA	Motor Power (HP)	Motor FLA	Catalog Code	Catalog Code	Catalog Code	Catalog Code
4001	1/8	0.3	1/3	0.6	URX000291	URX000651	URX000036	N/A
4002	1/4	0.6	1/3	0.8	URX000291	URX000651	URX000036	N/A
4004	1/2	1.1	1	2.1	URX000299	URX000410	URX000040	N/A
4005	1	2.1	2	3.0	URX000304	URX000504	05P00620-0110	URX000257
4007	1	2.1	2	3.4	URX000304	URX000504	05P00620-0111	URX000208
4009	2	3.4	3	4.8	URX000308	URX000414	05P00652-0213	URX000209
4012	2	3.4	3	4.8	URX000308	URX000414	05P00652-0213	URX000209
4018	2	3.4	3	5	URX000308	URX000414	05P00652-0213	URX000209
4023	3	4.8	5	8	URX000313	URX000417	URX000048	URX000210
4031	3	4.8	7.5	11	URX000316	URX000419	URX000052	URX000211
4038	5	7.6	10	14	URX000320	URX000421	URX000055	URX000223
4044	5	7.6	10	14	URX000320	URX000421	URX000055	URX000223
4060	7.5	11	15	21	URX000327	URX000425	URX000057	URX000184

1. This information reflects derating of three phase drives for single-phase input applications. See Single-Phase Converter to achieve full power with no derating on some drives.
2. Select partial catalog code from this single-phase table. Then get complete catalog code and list price from the Drive tables based on drive type in the GA500 Price Book.

Dimensions & Weights

IP20/Protected Chassis Dimensions

Figure 1: Drive Dimensions

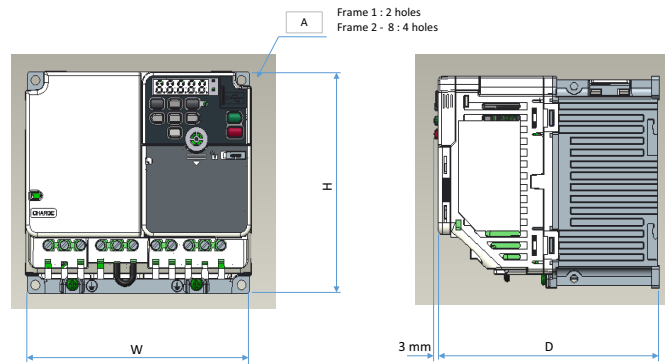

IP20/Protected Chassis Drive Without EMC Filter

Table 9: Dimensions without EMC Filter

Dimensions in (mm)			
Frame	Height	Width	Depth
1.1	5.04 (128)	2.68 (68)	2.99 (76)
1.2	5.04 (128)	2.68 (68)	4.25 (108)
1.3	5.04 (128)	2.68 (68)	4.65 (118)
1.4	5.04 (128)	2.68 (68)	5.04 (128)
2.1	5.04 (128)	4.25 (108)	3.19 (81)
2.2	5.04 (128)	4.25 (108)	3.90 (99)
2.3	5.04 (128)	4.25 (108)	5.08 (129)
2.4	5.04 (128)	4.25 (108)	5.41 (138)
2.5	5.04 (128)	4.25 (108)	6.06 (154)
3.1	5.04 (128)	5.51 (140)	5.63 (143)
3.2	5.04 (128)	5.51 (140)	6.42 (163)
4	5.04 (128)	6.69 (170)	7.09 (180)
5	10.24 (260)	5.51 (140)	5.51 (140)
6	11.81 (300)	7.09 (180)	5.63 (143)
7	13.78 (350)	8.66 (220)	7.36 (187)
8	13.78 (350)	7.48 (190)	8.03 (204)

Table 10: Dimensions with EMC Filter

Dimensions in (mm)			
Frame	Height	Width	Depth
1.1	5.04 (128)	2.68 (68)	4.57 (116)
1.2	5.04 (128)	2.68 (68)	5.83 (148)
1.3	5.04 (128)	2.68 (68)	6.22 (158)
1.4	5.04 (128)	2.68 (68)	6.61 (168)
2.1	5.04 (128)	4.25 (108)	4.96 (126)
2.2	5.04 (128)	4.25 (108)	5.67 (144)
2.3	5.04 (128)	4.25 (108)	6.85 (174)
2.4	5.04 (128)	4.25 (108)	7.19 (183)
2.5	5.04 (128)	4.25 (108)	7.83 (199)
3.1	5.04 (128)	5.51 (140)	7.60 (193)
3.2	5.04 (128)	5.51 (140)	7.99 (203)
5	10.24 (260)	5.51 (140)	7.72 (196)
6	11.81 (300)	7.09 (180)	7.72 (196)
7	13.78 (350)	8.66 (220)	8.50 (216)
8	13.78 (350)	7.48 (190)	9.88 (251)

Table 11: 240 V, Single-Phase Drives

Normal Duty (ND)	Heavy Duty (HD)	Catalog Code GA50U...	Output Amps		Weight lb (kg)	Frame
			ND	HD		
1/6	1/6	B001ABA	1.2	0.8	1.1 (0.5)	1.1
1/4	1/4	B002ABA	1.9	1.6		1.1
3/4	1/2	B004ABA	3.5	3	1.8 (0.8)	1.3
1.5	1	B006ABA	6	5	3.3 (1.5)	2.4
3	2	B010ABA	9.6	8		2.5
3	3	B012ABA	12.2	11	4.6 (2.1)	3.2
N/A	5	B018ABA	N/A	17.6	6.4 (2.9)	4

Table 12: 240 V, Three-Phase Drives

Normal Duty (ND)	Heavy Duty (HD)	Catalog Code GA50U...	Output Amps		Weight lb (kg)	Frame
			ND	HD		
1/6	1/6	2001	1.2	0.8	1.1 (0.5)	1.1
1/4	1/4	2002	1.9	1.6		1.1
3/4	1/2	2004	3.5	3.0	1.8 (0.8)	1.2
1.5	1	2006	6	5.0	2.0 (0.9)	1.4
3	2	2010	9.6	8.0	3.3 (1.5)	2.3
4	3	2012	12.2	11.0		2.4
7.5	5	2021	21	17.6	4.4 (2.2)	3.1
10	7.5	2030	30	25.0	7.5 (3.4)	5
15	10	2042	42	33.0	7.9 (3.6)	5
20	15	2056	56	47.0	12.1 (5.5)	6
25	20	2070	70	60.0	16.5 (7.5)	7
30	25	2082	82	75.0	17.6 (8.0)	7

Table 13: 480 V, Three-Phase Drives

Normal Duty (ND)	Heavy Duty (HD)	Catalog Code GA50U...	Output Amps		Weight lb (kg)	Frame
			ND	HD		
1/2	1/2	4001	1.2	1.2	1.8 (0.8)	2.1
1	3/4	4002	2.1	1.8	2.0 (0.9)	2.2
2	2	4004	4.1	3.4	3.53 (1.5)	2.4
3	3	4005	5.4	4.8		2.5
4	3	4007	7.1	5.6		2.5
5	4	4009	8.9	7.3		2.5
7.5	5	4012	11.9	9.2	4.4 (2.0)	3.1
10	10	4018	17.5	14.8	6.6 (3.0)	5
15	10	4023	23.4	18	7.1 (3.2)	5
20	15	4031	31	24	10.1 (4.6)	6
25	20	4038	38	31	10.6 (4.8)	6
30	25	4044	44	39	14.3 (6.5)	8
40	30	4060	60	45		8

Finless Drive Chassis Dimensions

Figure 2: Drive Dimensions

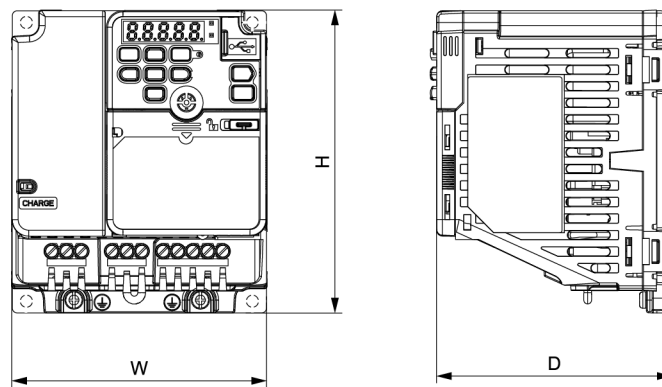

Finless Drive Dimensions

Table 14: 240 V, Single-Phase Drives

Model	Dimensions in (mm)			Weight lb (kg)
	W	H	D	
B001	2.68 (68)	5.04 (128)	2.80 (71)	1.32 (0.6)
B002	2.68 (68)	5.04 (128)	2.80 (71)	1.32 (0.6)
B004	2.68 (68)	5.04 (128)	3.19 (81)	1.32 (0.6)
B006	4.25 (108)	5.04 (128)	3.19 (81)	3.19 (0.9)
B010	4.25 (108)	5.04 (128)	3.64 (92.5)	2.20 (1.0)
B012	5.51 (140)	5.04 (128)	3.86 (98)	2.65 (1.2)

Table 15: 240 V, Three-Phase Drives

Model	Dimensions in (mm)			Weight lb (kg)
	W	H	D	
2001	2.68 (68)	5.04 (128)	2.80 (71)	1.32 (0.6)
2002	2.68 (68)	5.04 (128)	2.80 (71)	1.32 (0.6)
2004	2.68 (68)	5.04 (128)	2.80 (71)	1.32 (0.6)
2006	2.68 (68)	5.04 (128)	2.80 (71)	1.32 (0.6)
2010	4.25 (108)	5.04 (128)	2.85 (72.5)	1.76 (0.8)
2012	4.25 (108)	5.04 (128)	3.19 (81)	1.98 (0.9)
2021	5.51 (140)	5.04 (128)	3.07 (78)	2.65 (1.2)

Table 16: 480 V, Three-Phase Drives

Model	Dimensions in (mm)			Weight lb (kg)
	W	H	D	
4001	4.25 (108)	5.04 (128)	2.95 (75)	1.76 (0.8)
4002	4.25 (108)	5.04 (128)	2.95 (75)	1.76 (0.8)
4004	4.25 (108)	5.04 (128)	3.29 (83.5)	1.98 (0.9)
4005	4.25 (108)	5.04 (128)	3.94 (100)	2.20 (1.0)
4007	4.25 (108)	5.04 (128)	3.94 (100)	2.20 (1.0)
4009	4.25 (108)	5.04 (128)	3.94 (100)	2.20 (1.0)
4012	5.51 (140)	5.04 (128)	3.07 (78)	2.65 (1.2)

Drive Specifications

Power Ratings	
Item	Specification
Overload Capacity	110%/1 min. (Normal Duty) or 150%/1 min. (Heavy Duty)
Rated Voltage	200 to 240 VAC, -15 to +10%
	380 to 480 VAC, -15 to +10%
Capacity Range	240 V, Single-phase: 1/6 to 5 HP (0.1 to 3.7 kW)
	240 V, Three-Phase: 1/6 to 30 HP (0.1 to 22 kW)
	480 V, Three-Phase: 1/2 to 40 HP (0.2 to 30 kW)
Input Frequency	50/60 Hz +/-5%
Output Voltage Accuracy	+/-5%
Output Frequency	0 to 590 Hz (special software for up to 1000 Hz)
Control Method	V/f, Open Loop (IM/PM), Advanced Open Loop (PM), EZ Open Loop Vector
Motor Control	Induction Motor (IM), Permanent Magnet Motor (PM), Synchronous Reluctance Motor (SynRM)
Operating Environment	
Item	Specification
Ambient Temperature	-10 to +50°C (IP20/Protected Chassis), -10 to +40°C (UL Type 1), up to +60°C with derating
Storage Temperature	-40 to +70°C (short-term temperature during transportation)
Humidity	95% RH or less (non-condensing)
Altitude	Up to 1000 meters without derating, up to 4000 meters with output current and voltage derating
Shock	10 to 20 Hz: 9.8 m/s ²
	20 to 55 Hz: 5.9 m/s ²
Protection Design	IP20/Protected Chassis Standard, UL Type 1 kit optional
Mounting	Side-by-side, horizontal with derating, DIN rail, external heatsink
Conformal Coating (PCB's)	IEC 60721-3-3, Class 3C2 (chemical gases), Class 3S2 (solid particles)
Standards	CE, UL, cUL, KC, RCM, EAC, RoHS
Functional Safety	STO: IEC/EN61508 SIL3, PL _e

Network Communication Options

These cards, cables, and devices add control functionality to the standard drive. Items are shipped loose and unmounted.

Table 17: Option Cards

Option ¹	Purpose	Catalog Code
CANopen®	CAN based network option card supporting DS 301 and DSP 402 profiles as specified by CiA.	SI-S3
CC-Link	Fieldbus network option card managed by the CC-Link Partner Association (CLPA).	SI-C3
DeviceNet™	ODVA compliant option cards to connect to a DeviceNet network.	SI-N3
EtherCAT®	Option cards to turn the drive into an EtherCAT slave on the network.	SI-ES3
Ethernet/IP™	ODVA compliant option cards to connect to Ethernet/IP. (single port card)	SI-EN3
Ethernet/IP dual port	ODVA compliant option cards to connect to Ethernet/IP. (dual port card)	SI-EN3/D
MECHATROLINK-II	Option cards to turn the drive into a M-II node and connect to a high-speed MECHATROLINK-II network.	SI-T3
MECHATROLINK-III	Option cards to turn the drive into a M-III node and connect to a high-speed MECHATROLINK-III network.	SI-ET3
Modbus/TCP	Simple and effective solution to connect the drive to a Modbus TCP/IP network. (single port card)	SI-EM3
Modbus/TCP dual port	Simple and effective solution to connect the drive to a Modbus TCP/IP network. (dual port card)	SI-EM3/D
PROFIBUS-DP®	PI compliant option cards to connect to a PROFINET network.	SI-P3
PROFINET®	PI compliant option cards to connect to a PROFIBUS-DP network.	SI-EP3

1. Use of an option card requires the Option Card Carrier.

Table 18: Option Card Carrier

Option	Purpose	Catalog Code
Option Card Carrier	For use when installing a communication option card on the GA500.	JOHB-GA50

Keypad and Accessories

Additional Information	
Keypads, Cables, and Mounting Kits	

Table 19: Keypads

Catalog Code	Description
JVOP-KPLCA04MEB	LCD Keypad (standard, non-Bluetooth)
JVOP-KPLCC04MBB	LCD Keypad with Bluetooth







Standard LCD Keypad

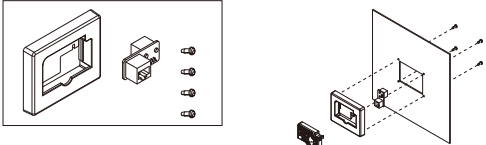

LCD Keypad with Bluetooth

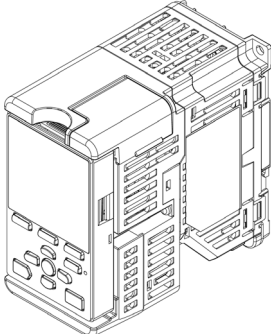
Table 20: Remote Mount Adapters

Catalog Code	Description	
ZPBA-GA500	UL Type 1 LED keypad mounting kit for standard GA500 keypad	
JVOP-KPBCH04AAA	Blank LED keypad when external mounting GA500 keypad (optional)	
JZSP-GA500	LCD keypad mounting kit (for mounting keypad onto drive	
900-192-933-001	UL Type 1 Keypad Panel Mount Kit A (brackets have tapped holes for use with screws) (For use with optional LCD keypad)	
900-192-933-002	UL Type 1 Keypad Panel Mount Kit B (brackets have untapped holes for use with panel studs) (For use with optional LCD keypad)	

Catalog Code	Description	
900-239-230-001	Outdoor UL Type 12/3/3R Keypad Panel Mount (For use with optional LCD keypad)	
UUX001955	Indoor/Outdoor UL Type 12/3/3R/4X Keypad Panel Mount (For use with optional LCD keypad)	

Table 21: Cables

Catalog Code	Description
UWR0051	Keypad Remote Mount Cable - 1 Meter
UWR0052	Keypad Remote Mount Cable - 3 Meter
UWR01258	USB Cable for PC to Drive Communication - 3 Meter

Table 22: Android Mobile Device Interface Cables (for connecting Android device to USB port on drive)

Catalog Code	Description
UWR01516-B	USB Mini-B to USB Micro-B. On-The-Go (OTG) compatible, 2-meter length
UWR01516-C	USB Mini-B to USB Type-C. On-The-Go (OTG) compatible, 2-meter length

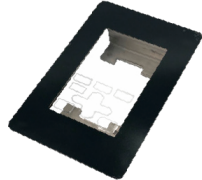
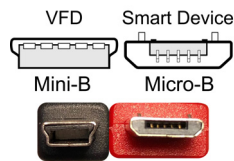

UWR01516-B - USB Mini-B to USB Micro-B

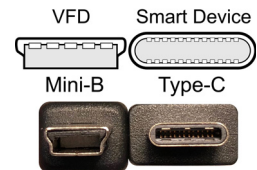

UWR01516-C - USB Mini-B to USB Type-C

Enclosure Adapters and Kits

These adapters are for mounting the standard IP20 drives directly to a wall, DIN Rail, a machine in a clean environment (UL Type 1), or inside a UL Type 1 enclosure with external heatsink. The UL Type 1 Adapters convert a Protected Chassis Drive (IP20) without EMC to an enclosed wall-mounted drive (UL Type 1).

Additional Information

Enclosure Adapters and Kits

IP20/UL Type 1 Adapters



This adapter turns the GA500 IP20/Protected Chassis into a GA500 UL Type 1 drive.

Table 23: 240 V, Single-Phase, IP20/UL Type 1 Adapter Kit

Catalog Code GA50U . . .	Type 1 Adapters
	Catalog Code
B001ABA	ZBAA-GA50V1-1
B002ABA	ZBAA-GA50V1-1
B004ABA	ZBAA-GA50V1-2
B006ABA	ZBAA-GA50V2-1
B010ABA	ZBAA-GA50V2-2
B012ABA	ZBAA-GA50V3-1
B018ABA	ZBAA-GA50V4-1

Table 24: 240 V, Three-Phase, IP20/UL Type 1 Adapter Kit

Catalog Code GA50U . .	Type 1 Adapters
	Catalog Code
2001ABA	ZBAA-GA50V1-1
2002ABA	ZBAA-GA50V1-1
2004ABA	ZBAA-GA50V1-1
2006ABA	ZBAA-GA50V1-1
2010ABA	ZBAA-GA50V2-3
2012ABA	ZBAA-GA50V2-1
2021ABA	ZBAA-GA50V3-2
2030ABA	ZBAA-GA50V5-1
2042ABA	ZBAA-GA50V5-1
2056ABA	ZBAA-GA50V6-1
2070ABA	ZBAA-GA50V7-1
2082ABA	ZBAA-GA50V7-1

Table 25: 480 V, Three-Phase, IP20/UL Type 1 Adapter Kit

Catalog Code GA50U . .	Type 1 Adapters
	Catalog Code
4001ABA	ZBAA-GA50V2-4
4002ABA	ZBAA-GA50V2-4
4004ABA	ZBAA-GA50V2-5
4005ABA	ZBAA-GA50V2-2
4007ABA	ZBAA-GA50V2-2
4009ABA	ZBAA-GA50V2-2
4012ABA	ZBAA-GA50V3-2
4018ABA	ZBAA-GA50V5-1
4023ABA	ZBAA-GA50V5-1
4031ABA	ZBAA-GA50V6-1
4038ABA	ZBAA-GA50V6-1
4044ABA	ZBAA-GA50V8-1
4060ABA	ZBAA-GA50V8-1

External Heatsink Adapters

These adapters are for mounting standard IP20/Protected Chassis drives with the heatsink external to an enclosure.

Figure 3: External Heatsink Adapters

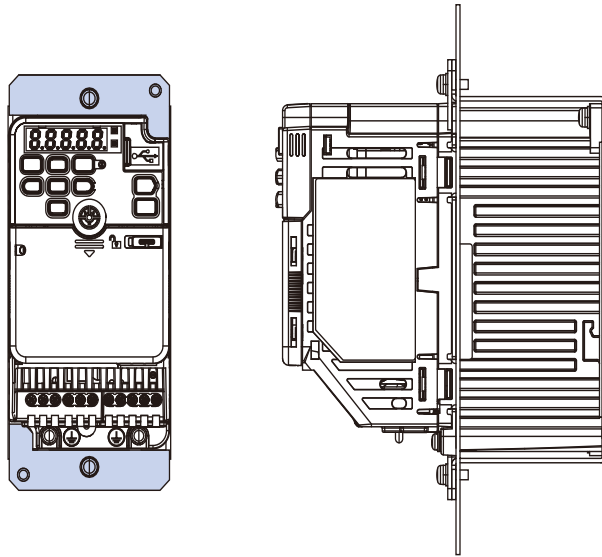

Table 26: 240 V, Single-Phase, Drive Mounting Adapters

Catalog Code GA50U . .	External Heatsink Adapter	
	Catalog Code	
B001*BA	ZPSA-GA50V1-1	
B002*BA	ZPSA-GA50V1-2	
B004*BA	ZPSA-GA50V2-2	
B006*BA	ZPSA-GA50V2-3	
B010*BA	ZPSA-GA50V3-1	
B012*BA	ZPSA-GA50V4-1	
B018*BA		

Table 27: 240 V, Three-Phase, Drive Mounting Adapters

Catalog Code GA50U . .	External Heatsink Adapter
	Catalog Code
2001*BA	ZPSA-GA50V1-1
2002*BA	
2004*BA	ZPSA-GA50V1-2
2006*BA	ZPSA-GA50V1-3
2010*BA	ZPSA-GA50V2-3
2012*BA	
2021*BA	ZPSA-GA50V3-1
2030*BA	ZPSA-GA50V5-1
2042*BA	
2056*BA	ZPSA-GA50V6-1
2070*BA	ZPSA-GA50V7-1
2082*BA	

Table 28: 480 V, Three-Phase, Drive Mounting Adapters

Catalog Code GA50U . .	External Heatsink Adapter
	Catalog Code
4001*BA	ZPSA-GA50V2-1
4002*BA	ZPSA-GA50V2-2
4004*BA	
4005*BA	ZPSA-GA50V2-3
4007*BA	
4009*BA	
4012*BA	ZPSA-GA50V3-1
4018*BA	ZPSA-GA50V5-1
4023*BA	
4031*BA	ZPSA-GA50V6-1
4038*BA	
4044*BA	ZPSA-GA50V8-1
4060*BA	

DIN Rail Mounting Adapters

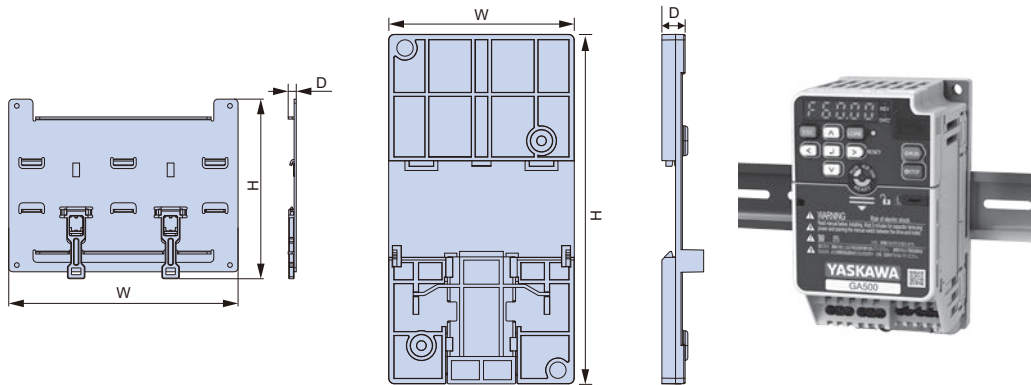

By utilizing the DIN rail attachment, equipped drives can be attached and detached with one touch. DIN adapters can be mounted on models with dimensions less than 170 mm wide and less than 128 mm in height.

Table 29: DIN Rail Adapter Kit Dimensions for GA500 IP20/Protected Chassis without EMC Filter

Catalog Code GA50U...	Dimensions in (mm)			Catalog Code
	Width	Height	Depth	
B001ABA	2.68 (68)	5.04 (128)	0.33 (8.5)	ZPZ-GA50V1
B002ABA				
B004ABA				
B006ABA	4.17 (106)	5.04 (128)	0.33 (8.5)	ZPZ-GA50V2
B010ABA				
B012ABA	5.43 (138)	5.04 (128)	0.33 (8.5)	ZPZ-GA50V3
B018ABA	6.69 (170)	5.24 (133)	0.24 (6.0)	EZZ08122D
2001ABA	2.68 (68)	5.04 (128)	0.33 (8.5)	ZPZ-GA50V1
2002ABA				
2004ABA				
2006ABA				
2010ABA	4.17 (106)	5.04 (128)	0.33 (8.5)	ZPZ-GA50V2
2012ABA				
2021ABA	5.43 (138)	5.04 (128)	0.33 (8.5)	ZPZ-GA50V3
4001ABA	4.17 (106)	5.04 (128)	0.33 (8.5)	ZPZ-GA50V2
4002ABA				
4004ABA				
4005ABA				
4007ABA				
4009ABA				
4012ABA	5.43 (138)	5.04 (128)	0.33 (8.5)	ZPZ-GA50V3

Power Options

Power options are add on devices that can be used to help increase power factor, improve harmonics, and dissipate regenerative energy.

Name	Purpose
EMC Filters	<ul style="list-style-type: none"> • IP20 rated • UL and cUL approved • Install external EMC filters to the drive input to comply with C2 levels of the EN 61800-3 EMC directive. • Provides electrical noise mitigation on the input side of the drive.
DC Bus Reactor	<ul style="list-style-type: none"> • Improves the drive input power factor. • Prevents damage to the drive when the power supply capacity is large. Only use this option when the power supply capacity is more than 600 kVA. • Decreases harmonic current • Improves the power supply total power factor.
AC Reactor	<ul style="list-style-type: none"> • Improves the drive input power factor. • Prevents damage to the drive when the power supply capacity is large. Only use this option when the power supply capacity is more than 600 kVA. • Decreases harmonic current • Improves the power supply total power factor.
3% Braking Resistor	Decreases the regenerative energy of the motor and decrease the deceleration time (Duty cycle of 3% ED). An installation attachment is required.
10% Braking Resistor Unit	Decreases the regenerative energy of the motor and decrease the deceleration time (Duty cycle of 10% ED). The unit contains a thermal overload relay.
Braking Unit	Use with a braking resistor unit to decrease motor deceleration times.
R1000	The R1000 regenerative module is used to divert energy generated by the motor back onto the line for use by other loads. The energy is directed back onto the line by taking DC voltage from the drive running the motor and converting it into a three-phase AC voltage waveform.
Single-Phase Converter	The Single Phase Converter is used in single-phase to three-phase conversion applications to eliminate drive derating. The Single Phase Converter significantly reduces stresses on the power grid with near unity power factor and less than 10% iTHD.

Additional Information

[GA500 Power Options](#)

EMC Filters



Provides electrical noise mitigation on the input side of the drive.

Table 30: 240 V, Single-Phase EMC Filters

Catalog Code GA50...	Part Number
B001A**	FS23638-10-07
B002A**	FS23638-10-07
B004A**	FS23638-10-07
B006A**	FS23638-20-07
B010A**	FS23638-20-07
B012A**	FS23638-30-07
B018A**	FS23638-40-07

Table 31: 240 V, Three-Phase EMC Filters

Catalog Code GA50...	Part Number
2001A**	FS23637-8-07
2002A**	FS23637-8-07
2004A**	FS23637-8-07
2006A**	FS23637-8-07
2010A**	FS23637-14-07
2012A**	FS23637-14-07
2021A**	FS23637-24-07
2030A**	FS5973-35-07
2042A**	FS5973-60-07
2056A**	FS5973-100-07
2070A**	FS5973-100-07
2082A**	Contact Factory

Table 32: 480 V, Three-Phase EMC Filters

Catalog Code GA50...	Part Number
4001A**	FS23639-5-07
4002A**	FS23639-5-07
4004A**	FS23639-5-07
4005A**	FS23639-10-07
4007A**	FS23639-10-07
4009A**	FS23639-10-07
4012A**	FS23639-15-07
4018A**	FS5972-35-07
4023A**	FS5972-35-07
4031A**	FS5972-60-07
4038A**	FS5972-60-07
4044A**	Contact Factory
4060A**	

EMC Filter Dimensions

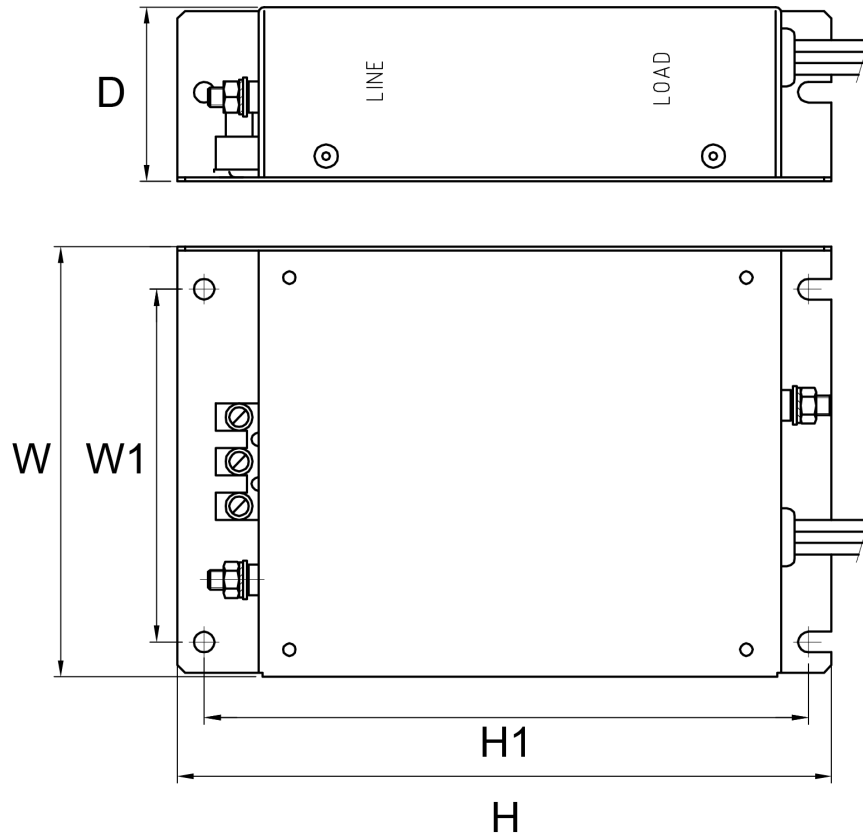

Table 33: EMC Filter Dimensions

EMC Filter Dimensions (mm)						
Model Number #	H	W	D	H1	W1	Wight (lbs)
FS23638-10-07	169	71	45	156	51	0.97
FS23638-20-07	169	111	50	156	91	1.76
FS23638-30-07	174	144	50	161	120	2.64
FS23638-40-07	174	174	50	161	150	3.52
FS23637-8-07	169	71	40	156	51	.88
FS23637-14-07	169	111	45	156	91	1.28
FS23637-24-07	174	144	50	161	120	1.98
FS5973-35-07	330	141	46	313	115	3.09
FS5973-60-07	335	206	60	336	175	6.61
FS5973-100-07	408	236	80	390	205	10.8
FS23639-5-07	169	111	45	156	91	1.1
FS23639-10-07	169	111	45	156	91	1.54
FS23639-15-07	174	144	50	161	120	1.98
FS5972-35-07	335	206	50	336	175	4.63
FS5972-60-07	408	236	65	390	205	8.82

DC Bus Reactors



Use a DC Bus Reactor on the DC bus terminals of a drive to reduce the effect of line-side transients and input current total harmonic distortion (THD). Large HP drives include a 3% bus impedance as standard. The DC bus reactor is available loose or in a separate UL Type 1 enclosure.

Table 34: 240 V, Three-Phase DC Bus Reactors

HP	Catalog Code GA50...		3% DC Bus Reactor				5% DC Bus Reactor			
	ND	HD	Open Type Catalog Code	Enclosed UL Type 1 Catalog Code	Amps	Inductance (mH)	Open Type Catalog Code	Enclosed UL Type 1 Catalog Code	Amps	Inductance (mH)
1/6	2001	2001	URX000042	URX000216	4	25	URX000039	URX000215	2	50
1/4	2002	2002	URX000041	URX000207	4	12	URX000042	URX000216	4	25
1/2	--	2004	URX000041	RURX000207	4	12	URX000041	URX000207	4	12
3/4	2004	--								
1	--	2006	05P00620-0111	URX000208	9	7.5	05P00620-0111	URX000208	9	7.5
1.5	2006	--								
2	--	2010	05P00620-0110	URX000257	9	3.22	05P00620-0111	URX000208	9	7.5
3	2010	--	05P00620-0110	URX000257	9	3.22	05P00620-0110	URX000257	9	3.22
	--	2012	URX000371	URX000258	12	2.1	05P00652-0213	URX000209	12	4
4	2012	--								
5	--	2021	05P00620-0115	URX000259	18	1.375	05P00652-0216	URX000220	18	3.75
7.5	2021	2030	URX000053	URX000212	25	1.275	URX000052	URX000211	25	1.75
10	2030	2042	URX000055	URX000223	32	1.62	URX000055	URX000223	32	1.62
15	2042	2056	URX000059	URX000262	50	0.625	URX000057	URX000184	40	1
20	2056	2070	URX000064	URX000213	62	0.61	URX000064	URX000213	62	0.61
25	2070	2082	URX000068	URX000214	80	0.4	URX000073	URX000265	92	0.6
30	2082	--	URX000072	URX000266	92	0.2	URX000073	URX000265	92	0.6

Table 35: 480 V, Three-Phase DC Bus Reactors

HP	Catalog Code GA50...		3% DC Bus Reactor				5% DC Bus Reactor			
	ND	HD	Open Type Catalog Code	Enclosed UL Type 1 Catalog Code	Amps	Inductance (mH)	Open Type Catalog Code	Enclosed UL Type 1 Catalog Code	Amps	Inductance (mH)
1/2	4001	4001	URX000039	URX000215	2	50	URX000039	URX000215	2	50
3/4	--	4002	URX000042	URX000216	4	25	URX000039	URX000215	2	50
1	4002	--								
2	4004	4004	05P00620-0109	URX000217	4	15	URX000042	URX000216	4	25
3	4005	4005	URX000044	URX000218	9	11.5	URX000042	URX000216	4	25
	--	4007	05P00620-0111	URX000208	9	7.5	URX000044	URX000218	9	11.5
4	4007	4009								
5	4009	4012	05P00620-0111	URX000208	9	7.5	URX000044	URX000218	9	11.5
7.5	4012	--	URX000046	URX000219	12	6	URX000046	URX000219	12	6
10	4018	4018	05P00652-0216	URX000220	18	3.75	URX000049	URX000260	18	6
	--	4023	URX000052	URX000211	25	1.75	URX000054	URX000224	25	4
15	4023	4031								
20	4031	4038	URX000056	URX000221	32	2.68	URX000056	URX000221	32	2.68
25	4038	4044	URX000058	URX000225	40	2.5	URX000058	URX000225	40	2.5
30	4044	4060	URX000057	URX000184	40	1	URX000058	URX000225	40	2.5
40	4060	--	URX000073	URX000265	92	0.6	URX000071	N/A	80	1.25

Open Type DC Bus Reactor Dimensions

Figure 4:

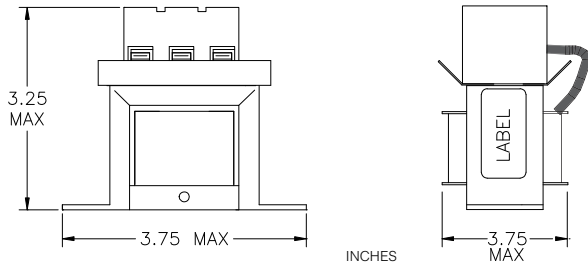

Figure 5:

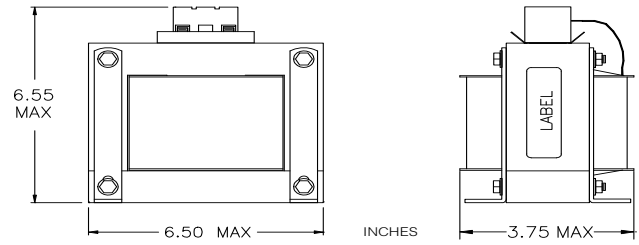

Figure 6:

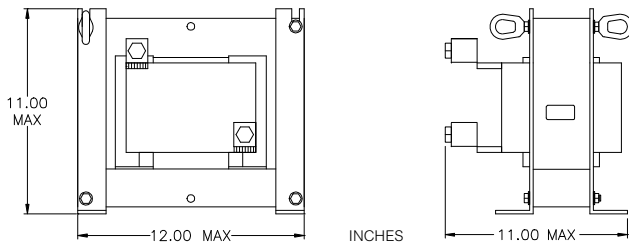
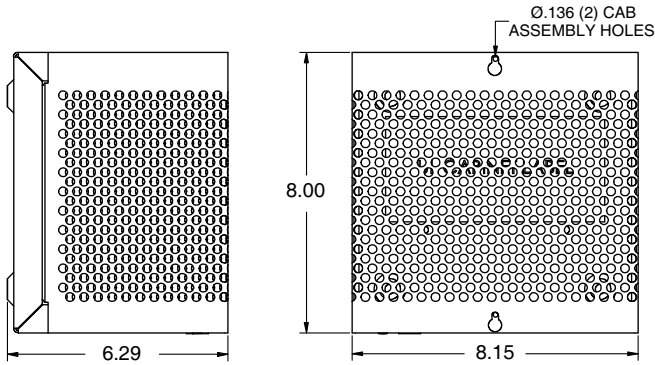

Table 36: Open Type DC Reactor Dimensions

DC Bus Reactor	Figure	DC Bus Reactor	Figure
05P00620-0109	4	URX000053	5
05P00620-0110	4	URX000054	5
05P00620-0111	5	URX000055	5
05P00620-0115	5	URX000056	5
05P00652-0213	5	URX000057	5
05P00652-0216	5	URX000058	5
URX000039	4	URX000059	5
URX000041	4	URX000064	6
URX000042	5	URX000068	6
URX000044	5	URX000071	6
URX000046	5	URX000072	6
URX000048	5	URX000073	6
URX000049	5	URX000371	5
URX000052	5		

Enclosed DC Reactor Dimensions

Figure 7: CAB-8



UNITS: INCHES

Figure 8: CAB-13V

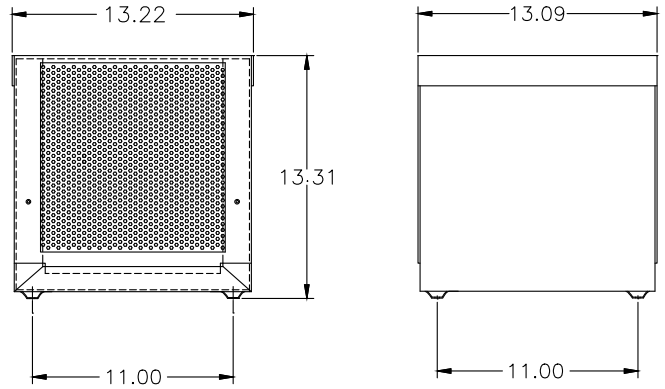

UNITS: INCHES

Table 37: Enclosed Type DC Reactor Dimensions

DC Bus Reactor	Figure	DC Bus Reactor	Figure
URX000184	7	URX000219	7
URX000207	7	URX000220	7
URX000208	7	URX000221	7
URX000209	7	URX000223	8
URX000210	7	URX000224	8
URX000211	7	URX000225	8
URX000212	7	URX000257	7
URX000213	8	URX000258	7
URX000214	8	URX000259	7
URX000215	7	URX000260	8
URX000216	7	URX000262	7
URX000217	7	URX000265	8
URX000218	7	URX000266	8

AC Input Reactors



3% and 5% impedance reactors may be used on either the input or output to reduce the effects of line or load side transients on the drive. The reactors listed are available loose or in a separate UL Type 1 enclosure.

Table 38: 240 V, Single-Phase, AC Input Reactors

HP	Catalog Code GA50...		3% Input Reactor				5% Input Reactor			
	ND	HD	Open Type Catalog Code	Enclosed UL Type 1 Catalog Code	Amps	Inductance (mH)	Open Type Catalog Code	Enclosed UL Type 1 Catalog Code	Amps	Inductance (mH)
1/6	B001	B001	URX000291	URX000651	2.1	5.3	URX000292	URX000502	2.1	11
1/4	B002	B002	URX000299	URX000410	4.8	2.3	URX000300	URX000503	4.8	4.8
1/2	--	B004	URX000303	URX000411	7.6	1.5	URX000304	URX000504	7.6	3
3/4	B004	--								
1	--	B006	URX000307	URX000413	11	1	URX000308	URX000414	11	2.1
1.5	B006	--								
2	--	B010	URX000315	URX000418	21	0.53	URX000316	URX000419	21	1.1
3	B010	--								
		B012	B012	URX000319	URX000420	28	0.39	URX000320	URX000421	28
5	--	B018	URX000319	URX000420	28	0.39	URX000320	URX000421	28	0.82

Table 39: 240 V, Three-Phase, AC Input Reactors

HP	Catalog Code GA50...		3% Input Reactor				5% Input Reactor			
	ND	HD	Open Type Catalog Code	Enclosed UL Type 1 Catalog Code	Amps	Inductance (mH)	Open Type Catalog Code	Enclosed UL Type 1 Catalog Code	Amps	Inductance (mH)
1/6	2001	2001	URX000283	URX000652	1.1	10	URX000284	URX000585	1.1	21
1/4	2002	2002	URX000291	URX000651	2.1	5.3	URX000292	URX000502	2.1	11
1/2	--	2004	URX000295	URX000409	3.4	3.2	URX000296	URX000584	3.4	6.8
3/4	2004	--								
1	--	2006	URX000299	URX000410	4.8	2.3	URX000300	URX000503	4.8	4.8
1.5	2006	--								
2	--	2010	URX000303	URX000411	7.6	1.5	URX000304	URX000504	7.6	3
3	2010	--	URX000307	URX000413	11	1	URX000308	URX000414	11	2.1
	--	2012	URX000307	URX000413	11	1	URX000308	URX000414	11	2.1
4	2012	--								
5	--	2021	URX000311	URX000415	14	0.79	URX000312	URX000416	14	1.6
7.5	2021	2030	URX000315	URX000418	21	0.53	URX000316	URX000419	21	1.1
10	2030	2042	URX000319	URX000420	28	0.39	URX000320	URX000421	28	0.82
15	2042	2056	URX000323	URX000422	35	0.35	URX000324	URX000423	35	0.71
20	2056	2070	URX000329	URX000501	55	0.27	URX000330	URX000553	55	0.48
25	2070	2082	URX000332	URX000426	65	0.19	URX000333	URX000554	65	0.38
30	2082	--	URX000335	URX000427	83	0.17	URX000336	URX000555	83	0.29

Table 40: 480 V, Three-Phase, AC Input Reactor

HP	Catalog Code GA50...		3% Input Reactor				5% Input Reactor			
	ND	HD	Open Type Catalog Code	Enclosed UL Type 1 Catalog Code	Amps	Inductance (mH)	Open Type Catalog Code	Enclosed UL Type 1 Catalog Code	Amps	Inductance (mH)
1/2	4001	4001	URX000280	URX000653	0.75	31	URX000281	URX000654	0.75	49
3/4	--	4002	URX000288	URX000551	1.6	14	URX000289	URX000571	1.6	23
1	4002	--								
2	4004	4004	URX000296	URX000584	3.4	6.8	URX000297	URX000573	3.4	11
3	4005	4005	URX000300	URX000503	4.8	4.8	URX000301	URX000552	4.8	7.7
	--	4007	URX000304	URX000504	7.6	3	URX000305	URX000574	7.6	4.8
4	4007	4009								
5	4009	4012	URX000304	URX000504	7.6	3	URX000305	URX000574	7.6	4.8
7.5	4012	--	URX000308	URX000414	11	2.1	URX000309	URX000505	11	3.3
10	4018	4018	URX000312	URX000416	14	1.6	URX000313	URX000417	14	2.6
	--	4023	URX000316	URX000419	21	1.1	URX000317	URX000568	21	1.8
15	4023	4031								
20	4031	4038	URX000320	URX000421	28	0.82	URX000321	URX000575	28	1.3
25	4038	4044	URX000320	URX000421	28	0.82	URX000321	URX000575	28	1.3
30	4044	4060	URX000324	URX000423	35	0.71	URX000325	URX000576	35	1.2
40	4060	--	URX000327	URX000425	46	0.55	URX000328	URX000577	46	0.98

AC Output Reactors



Output impedance reactors may be used to reduce the effects of load side transients on the drive. The reactors listed are available loose or in a separate UL Type 1 enclosure.

Table 41: 240 V, Single-Phase, AC Output Reactors

HP	Catalog Code GA50...		3% DC Bus Reactor			
	Normal Duty	Heavy Duty	Open Type Catalog Code	Enclosed UL Type 1 Catalog Code	Amps	Inductance (mH)
1/6	B001	B001	URX000080	URX000243	2	6
1/4	B002	B002	URX000080	URX000243	2	6
1/2	--	B004	05P00620-0017	05P00620-0020	4	3
3/4	B004	--				
1	--	B006	05P00620-0024	05P00620-0027	8	1.5
1.5	B006	--				
2	--	B010	05P00620-0134	05P00620-0032	12	1.25
3	B010	--				
		B012	B012	05P00620-0134	05P00620-0032	12
5	--	B018	05P00620-0136	05P00620-0036	18	0.8

Table 42: 240 V, Three-Phase, AC Output Reactors

HP	Catalog Code GA50...		3% Output Reactor			
	Normal Duty	Heavy Duty	Open Type Catalog Code	Enclosed UL Type 1 Catalog Code	Amps	Inductance (mH)
1/6	2001	2001	URX000080	URX000243	2	6
1/4	2002	2002	URX000080	URX000243	2	6
1/2	--	2004	05P00620-0017	05P00620-0020	4	3
3/4	2004	--				
1	--	2006	05P00620-0024	05P00620-0027	8	1.5
1.5	2006	--				
2	--	2010	05P00620-0024	05P00620-0027	8	1.5
3	2010	--	05P00620-0134	05P00620-0032	12	1.25
	--	2012	05P00620-0134	05P00620-0032	12	1.25
4	2012	--				
5	--	2021	05P00620-0136	05P00620-0036	18	0.8
7.5	2021	2030	URX000083	05P00620-0041	25	0.5
10	2030	2042	05P00620-0044	05P00620-0046	35	0.4
15	2042	2056	05P00620-0140	05P00620-0050	45	0.3
20	2056	2070	05P00620-0141	05P00620-0054	55	0.25
25	2070	2082	05P00620-0143	05P00620-0058	80	0.2
30	2082	--	URX000085	URX000204	100	0.15

Table 43: 480 V, Three-Phase, AC Output Reactors

HP	Catalog Code GA50...		3% Output Reactor			
	Normal Duty	Heavy Duty	Open Type Catalog Code	Enclosed UL Type 1 Catalog Code	Amps	Inductance (mH)
1/2	4001	4001	URX000078	URX000242	1	18
3/4	--	4002	05P00620-0131	05P00620-0015	2	12
1	4002	--				
2	4004	4004	05P00620-0132	05P00620-0021	4	6.5
3	4005	4005	05P00620-0025	05P00620-0029	8	5
	--	4007	05P00620-0133	05P00620-0028	8	3
4	4007	4009				
5	4009	4012	05P00620-0133	05P00620-0028	8	3
7.5	4012	--	05P00620-0135	05P00620-0033	12	2.5
10	4018	4018	05P00620-0137	05P00620-0037	18	1.5
	--	4023	05P00620-0138	05P00620-0042	25	1.2
15	4023	4031				
20	4031	4038	05P00620-0139	05P00620-0047	35	0.8
25	4038	4044	05P00620-0139	05P00620-0047	35	0.8
30	4044	4060	05P00620-0049	05P00620-0051	45	0.7
40	4060	--	05P00620-0142	05P00620-0055	55	0.5

AC Open Reactor Dimensions

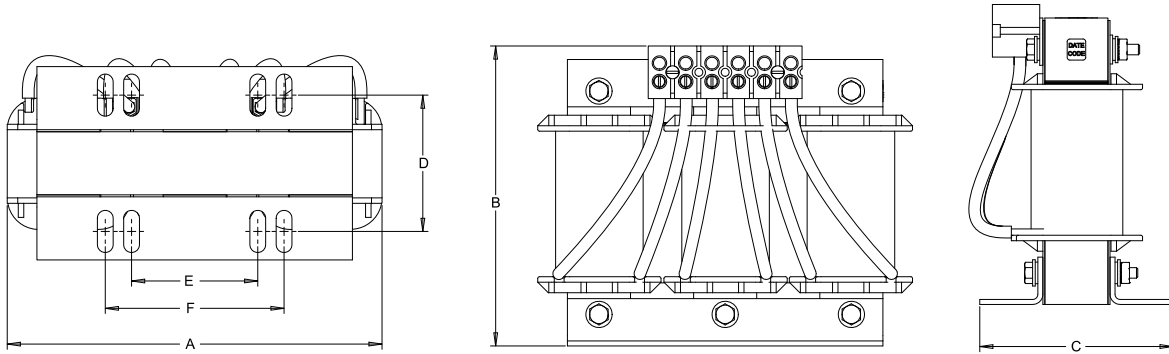

Table 44: AC Open Reactor Dimensions

Open Type Reactor Catalog Code	Watt Loss	Dimensions (mm/in)						Weight
		A	B	C	D	E	F	lb (kg)
05P00620-0017	14.5	106.7/4.2	101.6/4	66/2.6	50/2	37/1.4	65/2.6	4 (1.8)
05P00620-0024	19.5	149.9/5.9	116.8/4.6	73.7/2.9	53/2.1	51/2	76.2/3	7 (3.2)
05P00620-0025	25.3	149.9/5.9	119.4/4.7	83.8/3.3	67/2.6	51/2	76.2/3	11 (5.0)
05P00620-0044	49	180.3/7.1	144.8/5.7	94/3.7	66/2.6	76/3	76.2/3	14 (6.4)
05P00620-0049	62	226.1/8.9	182.9/7.2	116.8/4.6	80/3.2	76/3	108/4.3	26 (11.8)
05P00620-0131	7.5	106.7/4.2	101.6/4	66/2.6	50/2	37/1.4	65/2.6	4 (1.8)
05P00620-0132	20	106.7/4.2	101.6/4	66/2.6	50/2	37/1.4	65/2.6	4 (1.8)
05P00620-0133	29	149.9/5.9	116.8/4.6	73.7/2.9	53/2.1	51/2	76.2/3	8 (3.6)
05P00620-0134	26	149.9/5.9	127/5	81.3/3.2	53/2.1	51/2	76.2/3	9 (4.1)
05P00620-0135	31	149.9/5.9	127/5	81.3/3.2	53/2.1	51/2	76.2/3	10 (4.5)
05P00620-0136	36	149.9/5.9	129.5/5.1	81.3/3.2	54/2.1	51/2	76.2/3	9 (4.1)
05P00620-0137	43	149.9/5.9	129.5/5.1	88.9/3.5	63/2.5	51/2	76.2/3	12 (5.4)
05P00620-0138	52	180.3/7.1	147.3/5.8	86.7/3.4	60/2.4	76/3	76.2/3	14 (6.4)
05P00620-0139	54	180.3/7.1	147.3/5.8	94/3.7	70/2.8	76/3	76.2/3	16 (7.3)
05P00620-0140	54	226.1/8.9	180.3/7.1	116.8/4.6	80/3.2	76/3	108/4.3	22 (10)
05P00620-0141	64	228.6/9	175.3/6.9	134.6/5.3	80/3.2	76/3	108/4.3	24 (10.9)
05P00620-0142	67	228.6/9	175.3/6.9	134.6/5.3	80/3.2	76/3	108/4.3	26 (11.8)
05P00620-0143	82	226.1/8.9	175.3/6.9	144.8/5.7	88/3.5	92/3.63	108/4.3	25 (11.3)
URX000078	8	111.8/4.4	104.1/4.1	71.1/2.8	50/2	37/1.4	65/2.6	3 (1.4)
URX000080	10.7	106.7/4.2	101.6/4	66/2.6	44/1.7	37/1.4	65/2.6	3 (1.4)
URX000083	48	180.3/7.1	144.8/5.7	86.7/3.4	60/2.4	76/3	76.2/3	11 (5.0)
URX000085	94	226.1/8.9	177.8/7	152.4/6	88/3.5	92/3.62	108/4.3	29 (13.2)
URX000280	6.6	114.3/4.5	94/3.7	38.1/1.5	N/A	N/A	101.6/4	2 (0.9)
URX000281	8.8	114.3/4.5	94/3.7	38.1/1.5	N/A	N/A	101.6/4	2 (0.9)
URX000283	4.8	114.3/4.5	94/3.7	38.1/1.5	N/A	N/A	101.6/4	2 (0.9)
URX000284	7.8	114.3/4.5	94/3.7	38.1/1.5	N/A	N/A	101.6/4	2 (0.9)
URX000288	10.9	114.3/4.5	94/3.7	38.1/1.5	N/A	N/A	101.6/4	2 (0.9)
URX000289	15	114.3/4.5	94/3.7	38.1/1.5	N/A	N/A	101.6/4	2 (0.9)

Open Type Reactor Catalog Code	Watt Loss	Dimensions (mm/in)						Weight
		A	B	C	D	E	F	lb (kg)
URX000291	9	114.3/4.5	94/3.7	38.1/1.5	N/A	N/A	101.6/4	2 (0.9)
URX000292	14.3	114.3/4.5	94/3.7	38.1/1.5	N/A	N/A	101.6/4	2 (0.9)
URX000295	12.3	114.3/4.5	94/3.7	38.1/1.5	N/A	N/A	101.6/4	2 (0.9)
URX000296	19.6	114.3/4.5	94/3.7	38.1/1.5	N/A	N/A	101.6/4	2 (0.9)
URX000297	26.5	106.7/4.2	101.6/4	66/2.6	48.3/1.9	35.6/1.4	66/2.6	3 (1.4)
URX000299	13.8	114.3/4.5	94/3.7	38.1/1.5	N/A	N/A	101.6/4	2 (0.9)
URX000300	23	114.3/4.5	94/3.7	38.1/1.5	N/A	N/A	101.6/4	2 (0.9)
URX000301	37.5	106.7/4.2	101.6/4	66/2.6	48.3/1.9	35.6/1.4	66/2.6	3 (1.4)
URX000303	19.2	114.3/4.5	94/3.7	38.1/1.5	N/A	N/A	101.6/4	2 (0.9)
URX000304	37.2	106.7/4.2	101.6/4	66/2.6	48.3/1.9	35.6/1.4	66/2.6	3 (1.4)
URX000305	47.8	106.7/4.2	101.6/4	76.2/3	58.4/2.3	35.6/1.4	66/2.6	4 (1.8)
URX000307	26.8	106.7/4.2	104.1/4.1	66/2.6	48.3/1.9	35.6/1.4	66/2.6	3 (1.4)
URX000308	40.9	106.7/4.2	104.1/4.1	66/2.6	48.3/1.9	35.6/1.4	66/2.6	4 (1.8)
URX000309	54.4	106.7/4.2	104.1/4.1	83.8/3.3	63.5/2.5	35.6/1.4	66/2.6	5 (2.3)
URX000311	32.7	106.7/4.2	104.1/4.1	66/2.6	48.3/1.9	35.6/1.4	66/2.6	3 (1.4)
URX000312	48.2	106.7/4.2	104.1/4.1	76.2/3	58.4/2.3	35.6/1.4	66/2.6	4 (1.8)
URX000313	60.6	149.9/5.9	119.4/4.7	73.7/2.9	53.3/2.1	50.8/2	76.2/3	7 (3.2)
URX000315	38.3	106.7/4.2	132.1/5.2	76.2/3	58.4/2.3	35.6/1.4	66/2.6	4 (1.8)
URX000316	57.4	149.9/5.9	152.4/6	73.7/2.9	53.3/2.1	50.8/2	76.2/3	7 (3.2)
URX000317	73.5	149.9/5.9	152.4/6	83.8/3.3	63.5/2.5	50.8/2	76.2/3	10 (4.5)
URX000319	48.2	106.7/4.2	55.9/2.2	83.8/3.3	63.5/2.5	35.6/1.4	66/2.6	5 (2.3)
URX000320	66.8	149.9/5.9	152.4/6	83.8/3.3	63.5/2.5	50.8/2	76.2/3	10 (4.5)
URX000321	93.8	149.9/5.9	152.4/6	83.8/3.3	63.5/2.5	50.8/2	76.2/3	10 (4.5)
URX000323	69	149.9/5.9	152.4/6	88.9/3.5	71.1/2.8	50.8/2	76.2/3	10 (4.5)
URX000324	103	180.3/7.1	147.3/5.8	94/3.7	68.6/2.7	N/A	76.2/3	13 (5.9)
URX000325	122	180.3/7.1	147.3/5.8	106.7/4.2	81.3/3.2	N/A	76.2/3	18 (8.2)
URX000327	100	180.3/7.1	144.8/5.7	106.7/4.2	81.3/3.2	N/A	76.2/3	17 (7.7)
URX000328	179	226.1/8.9	210.8/8.3	116.8/4.6	81.3/3.2	76.2/3	109.2/4.3	24 (10.9)
URX000329	68	180.3/7.1	139.7/5.5	124.5/4.9	81.3/3.2	N/A	76.2/3	10 (4.5)
URX000330	110	180.3/7.1	142.2/5.6	142.2/5.6	81.3/3.2	N/A	76.2/3	20 (9.1)
URX000332	87	180.3/7.1	142.2/5.6	127/5	81.3/3.2	N/A	76.2/3	18 (8.2)
URX000333	105	180.3/7.1	144.8/5.7	152.4/6	81.3/3.2	N/A	76.2/3	18 (8.2)
URX000335	119	180.3/7.1	142.2/5.6	149.9/5.9	81.3/3.2	N/A	76.2/3	19 (8.6)
URX000336	155	226.1/8.9	180.3/7.1	147.3/5.8	81.3/3.2	76.2/3	109.2/4.3	26 (11.8)

Enclosed AC Reactor Dimensions

Figure 9: CAB-8

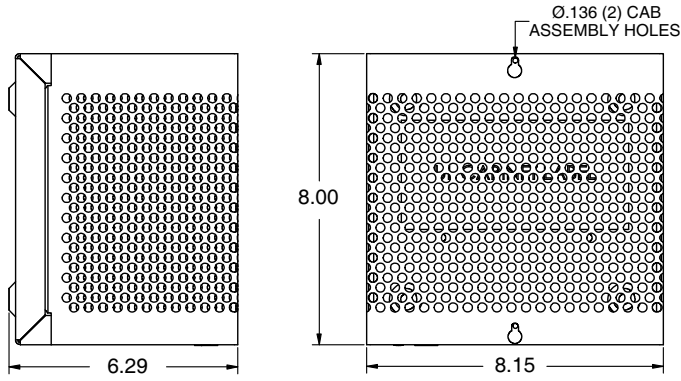

UNITS: INCHES

Figure 10: CAB-13V

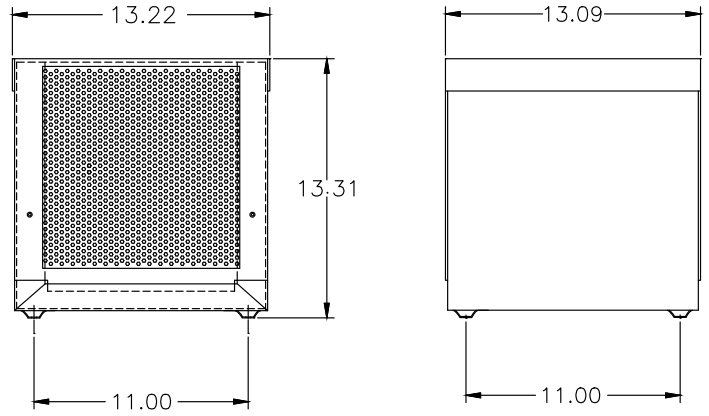

UNITS: INCHES

Table 45: AC Input/Output Enclosed Reactor Specifications

Enclosed UL Type 1 Reactor Catalog Code	Cabinet Reference (Figure)	Weight
		lb / kg
05P00620-0015	10	28 / 12.7
05P00620-0020		28.4 / 12.9
05P00620-0021		36 / 16.3
05P00620-0027		42 / 19.1
05P00620-0028		38 / 17.2
05P00620-0029		40 / 18.1
05P00620-0032		44 / 20
05P00620-0033		55 / 24.9
05P00620-0036	9	8.5 / 3.9
05P00620-0037		8.6 / 3.9
05P00620-0041		8.5 / 3.9
05P00620-0042		8.6 / 3.9
05P00620-0046		8.6 / 3.9
05P00620-0047		8.5 / 3.9
05P00620-0050		8.6 / 3.9
05P00620-0051		9.7 / 4.4
05P00620-0054		9.8 / 4.4
05P00620-0055		10 / 5
05P00620-0058		8.5 / 3.9
URX000204		8.5 / 3.9
URX000242		10 / 4.6
URX000243		10 / 5
URX000409		8.6 / 3.9
URX000410		8.7 / 3.9
URX000411		8 / 4
URX000413		9.7 / 4.4
URX000414		1.2 / 5.1
URX000415		9.8 / 4.4
URX000416	1.3 / 5.1	
URX000417	4.1 / 6.4	
URX000418	10	22.2 / 10.1
URX000419		25.2 / 11.4
URX000420		23.1 / 10.5
URX000421		27.5 / 12.5
URX000422		28 / 12.7
URX000423		31 / 14.1
URX000425		35 / 15.9
URX000426		36 / 16.3
URX000427		37 / 16.8
URX000501		36 / 16.3

Enclosed UL Type 1 Reactor Catalog Code	Cabinet Reference (Figure)	Weight
		lb / kg
URX000502	9	8.6 / 3.9
URX000503		8 / 4
URX000504		9.8 / 4.4
URX000505		2.3 / 5.6
URX000551		8.6 / 3.9
URX000552		9.8 / 4.4
URX000553	10	38 / 17.2
URX000554		40 / 18.1
URX000555		44 / 20
URX000568		28 / 12.7
URX000571	9	8.6 / 3.9
URX000573		9.7 / 4.4
URX000574		10 / 5
URX000575	10	28.4 / 12.9
URX000576		36 / 16.3
URX000577		42 / 19.1
URX000584	9	8.6 / 3.9
URX000585		8.6 / 3.9
URX000651		8.5 / 3.9
URX000652		8.5 / 3.9
URX000653		8.5 / 3.9
URX000654		8.5 / 3.9

Dynamic Braking Options



Additional Information	
Braking Resistor Specifications	Braking Resistor Drawings
Braking Connection Diagrams	

10% Dynamic Braking Options

Dynamic Braking Resistor, 10% Duty Cycle - are rated for 10% duty cycle over a 100 second interval. The resistors will achieve a minimum 150% peak braking torque for heavy duty horsepower ratings and a minimum of 100% peak braking power for normal duty horsepower ratings. These resistors are designed for separate panel mounting.

Table 46: 240 V, Single-Phase, 10% Dynamic Braking Options

Normal Duty HP	Heavy Duty HP	Catalog Code GA50...	10% Dynamic Braking Option (maximum 10 second on-time)				
			Resistor		Resistor Specifications		
			Catalog Code	Quantity	Resistance	Watts	Enclosure
1/6	1/6	B001	USR000032	1	750	600	GCE2
1/4	1/4	B002	USR000033	1	400	500	GCE1
3/4	1/2	B004	USR000022	1	200	250	GCE1
1.5	1	B006	USR000035	1	150	500	GCE1
3	2	B010	USR000024	1	70	250	GCE1
3	3	B012	USR000024	1	70	250	GCE1
N/A	5	B018	USR000025	1	40	846	GCE2

Table 47: 240 V, Three-Phase, 10% Dynamic Braking Options

Normal Duty HP	Heavy Duty HP	Catalog Code GA50...	10% Dynamic Braking Option (maximum 10 second on-time)				
			Resistor		Resistor Specifications		
			Catalog Code	Quantity	Resistance	Watts	Enclosure
1/6	1/6	2001	USR000032	1	750	600	GCE2
1/4	1/4	2002	USR000033	1	400	500	GCE1
3/4	1/2	2004	USR000022	1	200	250	GCE1
1.5	1	2006	USR000035	1	150	500	GCE1
3	2	2010	USR000024	1	70	250	GCE1
4	3	2012	USR000024	1	70	250	GCE1
7.5	5	2021	USR000025	1	40	846	GCE2
10	7.5	2030	URS000148	1	18	1300	GCE3
15	10	2042	URS000140	1	13.6	1645	GCE4
20	15	2056	URS000136	1	10.5	3402	GCE9
25	20	2070	URS000136	1	10.5	3402	GCE9
30	25	2082	URS000136	1	10.5	3402	GCE9

Table 48: 480 V, Three-Phase, 10% Dynamic Braking Options

Normal Duty HP	Heavy Duty HP	Catalog Code GA50...	10% Dynamic Braking Option (maximum 10 second on-time)				
			Resistor		Resistor Specifications		
			Catalog Code	Quantity	Resistance	Watts	Enclosure
1/2	1/2	4001	USR000032	1	750	600	GCE2
1	3/4	4002	USR000032	1	750	600	GCE2
2	2	4004	USR000032	1	750	600	GCE2
3	3	4005	USR000034	1	250	500	GCE1
4	3	4007	USR000034	1	250	500	GCE1
5	4	4009	USR000035	1	150	500	GCE1
7.5	5	4012	USR000036	1	100	975	GCE2
10	10	4018	USR000038	1	50	1600	GCE4
15	10	4023	USR000038	1	50	1600	GCE4
20	15	4031	USR000039	1	40	2050	GCE6
25	20	4038	URS000154	1	27.2	2720	GCE8
30	25	4044	URS000154	1	27.2	2720	GCE8
40	30	4060	USR000066	1	20	4775	GCE9

Dimension Drawings

DD.GCE.01

Figure 11: GCE Type Enclosure
FRONT VIEW

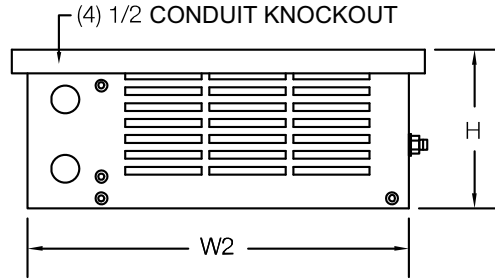

TOP VIEW

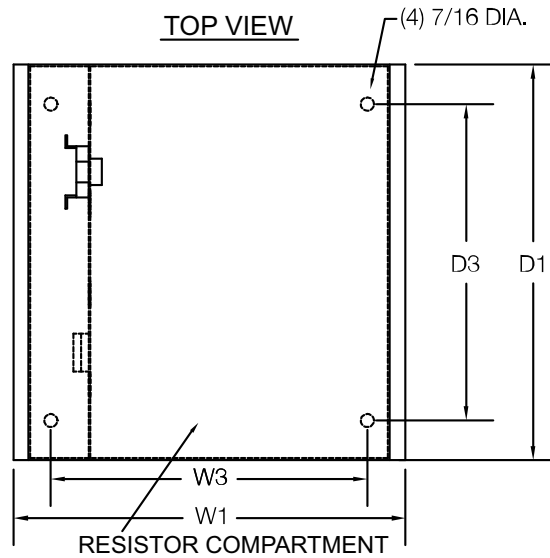

Table 49: GCE Type Enclosure Dimensions

Model	Dimensions in (mm)						
	W1	W2	W3	D1	D2	D3	H
GCE1	12.5 (317.5)	12 (304.8)	10.5 (266.7)	5.13 (130.3)	5 (127)	-	5 (127)
GCE2	12.5 (317.5)	12 (304.8)	10.5 (266.7)	7.13 (181.1)	7 (177.8)	4.5 (114.3)	5 (127)
GCE3	12.5 (317.5)	12 (304.8)	10.5 (266.7)	10.13 (257.3)	10 (254)	7.5 (190.5)	5 (127)
GCE4	12.5 (317.5)	12 (304.8)	10.5 (266.7)	13.13 (333.5)	13 (330.2)	10.5 (266.7)	5 (127)
GCE5	12.5 (317.5)	12 (304.8)	10.5 (266.7)	16.13 (409.7)	16 (406.4)	13.5 (342.9)	5 (127)
GCE6	19.5 (495.3)	19 (482.6)	17.5 (444.5)	10.13 (257.3)	10 (254)	7.5 (190.5)	5 (127)
GCE8	19.5 (495.3)	19 (482.6)	17.5 (444.5)	13.13 (333.5)	13 (330.2)	10.5 (266.7)	5 (127)
GCE9	27 (685.8)	26.5 (673.1)	25 (635)	10.13 (257.3)	10 (254)	7.5 (190.5)	5 (127)

3% Dynamic Braking Options

3% Duty cycle resistors are rated for a 3% duty cycle at 100 second intervals.

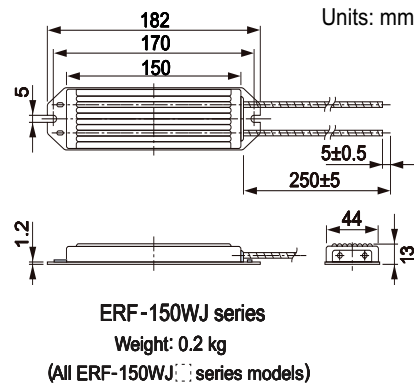

Table 50: 240 V, Single-Phase, 3% Dynamic Braking Options

Normal Duty HP	Heavy Duty HP	Catalog Code GA50...	Resistor ¹			
			Catalog Code	Quantity	Ohms (each)	Watts
1/6	1/6	B001	R7508	1	750	150
1/4	1/4	B002	R7507	1	400	150
3/4	1/2	B004	R7506	1	300	150
1.5	1	B006	R7505	1	200	150
3	2	B010	R7504	1	100	150
3	3	B012	R7510	1	62	150
N/A	5	B018	R7510	2	62	150

1. These resistors offer approximately 100% peak braking power.

Table 51: 240 V, Three-Phase, 3% Dynamic Braking Options

Normal Duty HP	Heavy Duty HP	Catalog Code GA50...	Resistor ¹			
			Catalog Code	Quantity	Ohms (each)	Watts
1/6	1/6	2001	R7508	1	750	150
1/4	1/4	2002	R7507	1	400	150
3/4	1/2	2004	R7506	1	300	150
1.5	1	2006	R7505	1	200	150
3	2	2010	R7504	1	100	150
4	3	2012	R7510	1	62	150
7.5	5	2021	R7510	2	62	150

1. These resistors offer approximately 100% peak braking power.

Table 52: 480 V, Three-Phase, 3% Dynamic Braking Options

Normal Duty HP	Heavy Duty HP	Catalog Code GA50...	Resistor ¹			
			Catalog Code	Quantity	Ohms (each)	Watts
1/2	1/2	4001	R7508	1	750	150
1	3/4	4002	R7508	1	750	150
2	2	4004	R7507	1	400	150
3	3	4005	R7505	1	200	150
4	3	4007	R7505	1	200	150
5	4	4009	R7505	1	200	150
7.5	5	4012	R7504	1	100	150

1. These resistors offer approximately 100% peak braking power.

R1000 Regenerative Systems



- Compatible with all conventional drives having full power access to DC bus
- Rated for 100% power, 25% duty cycle (60 seconds maximum on time), or 80% continuous
- 0.9 Power Factor at full load
- Overload capability of 150% for 30 seconds
- Overcurrent and Overheat Protection

Additional Information		
R1000 Online Resources	Flyer	Manual

Each R1000 regenerative unit requires the following:

- **R1000:** The R1000 regenerative module is used to divert energy generated by the motor back onto the line for use by other loads. The energy is directed back onto the line by taking DC voltage from the drive running the motor and converting it into a three phase AC voltage waveform.
- **Power Coordination Reactor:** The power coordination reactor provides impedance to limit peak current. The power coordination reactor represents minimum impedance required to limit current to levels acceptable to the R1000.
- **Fuses and Fuse Holder:** Recommended fusing and their corresponding holder(s) is provided for device protection and UL certification.
- **Current Suppression Reactor:** The current suppression reactor provides impedance to protect the connected drive's input section from peak current that may result from the R1000 IGBT switching section. The current suppression reactor provides isolation from the dv/dt of the R1000 switching section.

Typical Applications

Stopping
Elevators and Lifts
Centrifuges
Saws
Large Fans
Machine Tool Spindles

Cyclic Loading
Presses
Dryers
Vibratory Equipment

Continuous Regeneration
Winders
Downhill Conveyors
Dynamometers

Note: The R1000 is not suitable to use with single-phase products.

Table 53: 240 V, Three-Phase, R1000 Regenerative Systems

Motor Power HP	Catalog Code GA50U..		R1000 Catalog Code CIMR-RU... ^{1 2}	Current Suppression Reactor Catalog Code	Power Coordination Reactor Catalog Code	Fuses (Quantity: 3) Catalog Code	Fuse Holder	
	Normal Duty	Heavy Duty					Catalog Code	Quantity
5	--	2021	2A03P5FAA	05P00620-0134	05P00620-0136	FU-002031	FU-002055	1
7.5	2021	2030	2A0005FAA	URX000083	05P00620-0138	FU-002031	FU-002055	
10	2030	2042	2A0007FAA	URX000083	05P00620-0044	FU-002032	FU-002055	
15	2042	2056	2A0010FAA	05P00620-0044	05P00620-0140	UFU000153	FU-002082	3
20	2056	2070	2A0014FAA	05P00620-0141	05P00620-0141	UFU000479	FU-002082	
25	2070	2082	2A0017FAA	05P00620-0143	05P00620-0143	UFU000154	FU-002083	
30	2082	--	2A0020FAA	URX000085	05P00620-0143	UFU000155	FU-002083	

1. IP20/UL Type 1 enclosure is standard for CIMR-RU2A03P5FAA through CIMR-RU2A0020FAA
2. IP00/Open Chassis are standard for CIMR-RU2A0053AAA through CIMR-RU2A0105AAA

Table 54: 480 V, Three-Phase, R1000 Regenerative Systems

Motor Power HP	Catalog Code GA50U..		R1000 Catalog Code CIMR-RU... ^{1 2}	Current Suppression Reactor Catalog Code	Power Coordination Reactor Catalog Code	Fuses (Quantity: 3) Catalog Code	Fuse Holder	
	Normal Duty	Heavy Duty					Catalog Code	Quantity
5	4009	4012	4A03P5FAA	05P00620-0025	05P00620-0133	FU-002030	FU-002055	1
7.5	4012	4018	4A0005FAA	05P00620-0133	05P00620-0135	FU-002030	FU-002055	
10	4018	4023	4A0007FAA	05P00620-0135	05P00620-0137	FU-002030	FU-002055	
15	4023	4031	4A0010FAA	05P00620-0137	05P00620-0138	FU-002032	FU-002055	
20	4031	4038	4A0014FAA	URX000083	05P00620-0139	FU-002032	FU-002055	
25	4038	4044	4A0017FAA	05P00620-0044	05P00620-0139	FU-000783	FU-002082	3
30	4044	4060	4A0020FAA	05P00620-0049	05P00620-0049	FU-000783	FU-002082	
40	4060	--	4A0028FAA	05P00620-0142	05P00620-0142	UFU000480	FU-002082	

1. IP20/UL Type 1 enclosure is standard for CIMR-RU4A03P5FAA through CIMR-RU4A0028FAA
2. IP00/Open Chassis are standard for CIMR-RU2A0053AAA through CIMR-RU2A0105AAA

Reactor Dimensions

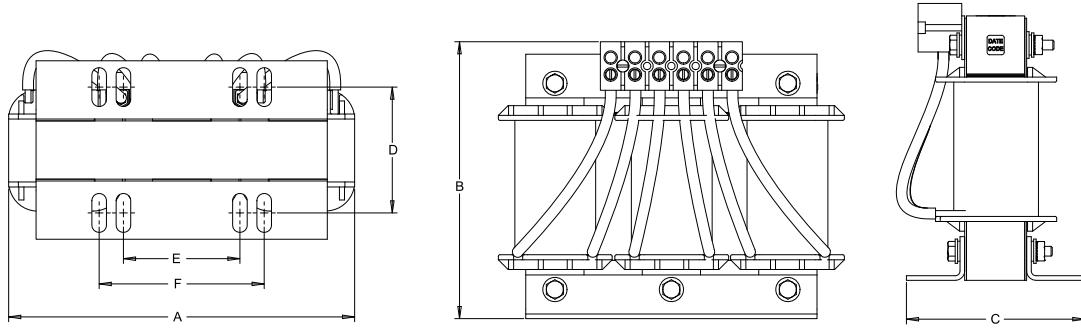

Table 55: R1000 Reactor Dimensions (Open Type)

Reactor Catalog Code	Current Rating (A)	Inductance (mH)	Watt Loss	Dimensions (mm/in)					Weight lb/kg
				A	B	C	D	E	
05P00620-0025	8	5	25.3	152/6.0	122/4.8	86/3.4	67/2.62	51/2.00	11/5.0
05P00620-0044	35	0.4	49	183/7.2	147/5.8	102/4.0	66/2.60	76/3.00	14/6.4
05P00620-0049	45	0.7	62	229/9.0	188/7.4	119/4.7	80/3.16	76/3.00	28/13
05P00620-0133	8	3	29	152/6.0	122/4.8	76/3.0	53/2.10	51/2.00	8/3.6
05P00620-0134	12	1.25	26	152/6.0	127/5.0	84/3.3	53/2.10	51/2.00	9/4.1
05P00620-0135	12	2.5	31	152/6.0	127/5.0	84/3.3	53/2.10	51/2.00	10/4.5
05P00620-0136	18	0.8	36	152/6.0	135/5.3	81/3.2	54/2.10	51/2.00	9/4.1
05P00620-0137	18	1.5	43	152/6.0	135/5.3	89/3.5	63/2.48	51/2.00	12/5.5
05P00620-0138	25	1.2	52	183/7.2	147/5.8	89/3.5	60/2.35	76/3.00	14/6.4
05P00620-0139	35	0.8	54	183/7.2	147/5.8	102/4.0	70/2.75	76/3.00	16/7.3
05P00620-0140	45	0.3	54	229/9.0	188/7.4	119/4.7	80/3.16	76/3.00	23/13
05P00620-0141	55	0.25	64	229/9.0	185/7.3	135/5.3	80/3.16	76/3.00	24/11
05P00620-0142	55	0.5	67	229/9.0	178/7.0	135/5.3	80/3.16	76/3.00	27/12
05P00620-0143	80	0.2	82	229/9	183/7.2	160/6.3	88/3.47	92/3.63	43/20
URX000083	25	0.5	48	183/7.2	147/5.8	89/3.5	60/2.35	76/3.00	11/5.0
URX000085	100	0.15	94	229/9	185/7.3	165/6.5	88/3.46	92/3.62	47/21

R1000 External Heatsink Kits

External Heatsink Kit: Allows drives to be mounted with the drive's heatsink external (NEMA 1 backside) to the enclosure. Option kit for customer mounting. Larger standard drives include brackets.

Table 56: 240 Volt Models, R1000 External Heatsink Kit for UL Type 1

Rated Input Voltage	Drive Model Number CIMR-RU2A . .	Catalog Code
200 to 240 Volt Three-Phase	03P5	EZZ020800B
	0005	
	0007	
	0010	EZZ020800C
	0014	
	0017	EZZ020800D
	0020	

Table 57: 480 Volt Models, R1000 External Heatsink Kits for UL Type 1

Rated Input Voltage	Drive Model Number CIMR-RU4A . .	Catalog Code
400 to 480 Volt Three-Phase	03P5	EZZ020800B
	0005	
	0007	
	0010	EZZ020800C
	0014	
	0017	EZZ020800D
	0020	
	0028	

Single Phase Converter



Yaskawa’s industry leading Single Phase Converter (SPC) cleanly converts single-phase AC power to DC power for Yaskawa variable frequency drives. The SPC combines Yaskawa reliability and drive technology with motor control solutions for businesses in remote areas. The SPC eliminates the need to oversize variable frequency drives for single-phase applications while reducing distortion to less than 10% iTHD. With lower input harmonics and near unity power factor, the SPC also eliminates the need to significantly oversize transformers in single-phase applications, reducing overall installation costs. The Single Phase Converter addresses these common issues with AC motors powered from single-phase input:

- Limited single-phase motor options.
- Inefficient use of power due to choppy current harmonics.
- Increased maintenance of rotating parts and tuned circuits.

Item	Specification
Power Range	230 VAC: 20-60 HP
	460 VAC: 30-125 HP
Input Voltage Tolerance	230-240 V, Single-Phase
	460-480 V, Single-Phase
	Tolerance -5/+10 % ¹
Power Factor	0.99
Ambient Operating Temperature	-10 to 50 °C (14 to 122 °F) Open Chassis
Global Certifications	UL, RoHS
User Interface	4 LED indicators: Power, Ready, Run, Fault

1. -10 % Minimum input voltage for 60 seconds at rated power.

Additional Information	
Single Phase Converter Specifications	Manual
	Drawings

Table 58: Single-Phase Converters - 20 to 125 HP

Power Supply	System Kit Number ¹	Rated Power HP ²	Input Current (Amps)	Output Current (Amps)	Height (mm)	Width (mm)	Depth (mm)
230 - 240 Vac	SPBC-240-20HP	20	79	57	16.7 (423)	10 (254)	10 (254)
	SPBC-240-30HP	30	116	84	16.7 (423)	10 (254)	10 (254)
	SPBC-240-40HP	40	154	112	20.7 (525)	12 (305)	10.5 (267)
	SPBC-240-50HP	50	191	138	25 (636)	12.2 (310)	11.42 (290)
	SPBC-240-60HP	60	228	165	25 (636)	12.2 (310)	11.42 (290)
460 - 480 Vac	SPBC-480-30HP	30	58	42	16.7 (423)	10 (254)	10 (254)
	SPBC-480-40HP	40	77	56	16.7 (423)	10 (254)	10 (254)
	SPBC-480-50HP	50	96	69	17 (432)	12 (305)	10.5 (267)
	SPBC-480-60HP	60	114	83	17 (432)	12 (305)	10.5 (267)
	SPBC-480-75HP	75	142	103	25 (636)	12.2 (310)	11.42 (290)
	SPBC-480-125HP	125	234	169	25 (636)	12.2 (310)	14.8 (375)

1. The kit includes open type/IP20 protected Chassis Single-Phase Converter and DC link choke.
2. The larger power Single Phase Converter unit may be used on lower power motors.

GA500 Drive Derating

Carrier Frequency

Table 59: 240 V, Single-Phase, Carrier Frequency Derating

Catalog Code GA50U..	Carrier Frequency Derating ^{1 2}											
	Heavy Duty Rating Amps						Normal Duty Rating Amps					
	2 kHz	5 kHz	8 kHz	10 kHz	12.5 kHz	15 kHz	2 kHz	5 kHz	8 kHz	10 kHz	12.5 kHz	15 kHz
B001	0.8	0.8	0.8	0.8	0.7	0.64	1.2	1.1	1	0.9	0.8	0.64
B002	1.6	1.6	1.6	1.6	1.4	1.3	1.9	1.9	1.7	1.6	1.4	1.3
B004	3	3	3	3	2.7	2.4	3.5	3.5	3.2	3	2.7	2.4
B006	5	5	5	5	4.5	4	6	6	5.4	5	4.5	4
B010	8	8	8	7.5	7	6.4	9.6	9.1	8.3	7.7	7.1	6.4
B012	11	11	11	10.4	9.6	8.8	12.2	11.9	11	10.4	9.6	8.8
B018	17.6	17.6	17.6	16.6	15.3	14.1	21	19.8	18.1	17	15.5	14.1

1. Applicable Motor Control Methods: GA500 Parameter A1-02 = 0, 2, 5, 8.
2. Refer to the GA500 Technical Manual for AOLV/PM Carrier Frequency Derating information.

Table 60: 240 V, Single-Phase, Carrier Frequency Derating (Permanent Magnet (PM) Control)

Catalog Code GA50U..	Carrier Frequency Derating ^{1 2}											
	Heavy Duty Rating Amps						Normal Duty Rating Amps					
	2 kHz	4 kHz	6 kHz	8 kHz	10 kHz	12 kHz	2 kHz	4 kHz	6 kHz	8 kHz	10 kHz	12 kHz
B001	0.8	0.8	0.8	0.7	0.6	0.5	1.2	1.1	0.9	0.8	0.6	0.5
B002	1.6	1.6	1.6	1.5	1.3	1.1	1.9	1.9	1.7	1.5	1.3	1.1
B004	3	3	3	2.8	2.4	2	3.5	3.5	3.1	2.8	2.4	2
B006	5	5	5	4.6	4	3.4	6	5.8	5.2	4.6	4	3.4
B010	8	8	7.8	7.1	6.4	5.7	9.6	8.8	8	7.2	6.4	5.6
B012	11	11	10.7	9.7	8.8	7.9	12.2	11.6	10.7	9.7	8.8	7.9
B018	17.6	17.6	17.1	15.6	14.1	12.6	21	19.3	17.5	15.8	14.1	12.3

1. Applicable Motor Control Methods: GA500 Parameter A1-02 = 6.
2. Refer to the GA500 Technical Manual for AOLV/PM Carrier Frequency Derating information.

Table 61: 240 V, Three-Phase, Carrier Frequency Derating

Catalog Code GA50U..	Carrier Frequency Derating ^{1 2}											
	Heavy Duty Rating Amps						Normal Duty Rating Amps					
	2 kHz	5 kHz	8 kHz	10 kHz	12.5 kHz	15 kHz	2 kHz	5 kHz	8 kHz	10 kHz	12.5 kHz	15 kHz
2001	0.8	0.8	0.8	0.8	0.7	0.6	1.2	1.1	1	0.9	0.8	0.6
2002	1.6	1.6	1.6	1.6	1.4	1.3	1.9	1.9	1.7	1.6	1.4	1.3
2004	3	3	3	3	2.7	2.4	3.5	3.5	3.2	3	2.7	2.4
2006	5	5	5	5	4.5	4	6	6	5.4	5	4.5	4
2010	8	8	8	7.5	7	6.4	9.6	9.1	8.3	7.7	7.1	6.4
2012	11	11	11	10.4	9.6	8.8	12.2	11.9	11	10.4	9.6	8.8
2021	17.6	17.6	17.6	16.6	15.3	14.1	21	19.8	18.1	17	15.5	14.1
2030	25	25	25	23.6	21.8	20	30	28.3	25.8	24.2	22.1	20
2042	33	33	33	31.1	28.8	26	42	39.4	35.5	32.9	29.7	26
2056	47	47	47	44.3	41	38	56	52.9	48.3	45.3	41.4	38
2070	60	60	60	56.6	52.3	48	70	66.3	60.8	57.2	52.6	48
2082	75	75	75	70.7	65.4	60	82	81.4	75	70.7	65.4	60

1. Applicable Motor Control Methods: GA500 Parameter A1-02 = 0, 2, 5, 8.
2. Refer to the GA500 Technical Manual for AOLV/PM Carrier Frequency Derating information.

Table 62: 240 V, Three-Phase, Carrier Frequency Derating (Permanent Magnet (PM) Control)

Catalog Code GA50U..	Carrier Frequency Derating ^{1 2}											
	Heavy Duty Rating Amps						Normal Duty Rating Amps					
	2 kHz	4 kHz	6 kHz	8 kHz	10 kHz	12 kHz	2 kHz	4 kHz	6 kHz	8 kHz	10 kHz	12 kHz
2001	0.8	0.8	0.8	0.7	0.6	0.5	1.2	1.1	0.9	0.8	0.6	0.5
2002	1.6	1.6	1.6	1.5	1.3	1.1	1.9	1.9	1.7	1.5	1.3	1.1
2004	3	3	3	2.8	2.4	2	3.5	3.5	3.1	2.8	2.4	2
2006	5	5	5	4.6	4	3.4	6	5.8	5.2	4.6	4	3.4
2010	8	8	7.8	7.1	6.4	5.7	9.6	8.8	8	7.2	6.4	5.6
2012	11	11	10.7	9.7	8.8	7.9	12.2	11.6	10.7	9.7	8.8	7.9
2021	17.6	17.6	17.1	15.6	14.1	12.6	21	19.3	17.5	15.8	14.1	12.4
2030	25	25	24.3	22.1	20	17.9	30	27.5	25	22.5	20	17.5
2042	33	33	32.1	29.2	26.4	23.6	42	38.1	34.2	30.3	26.4	22.5
2056	47	47	45.7	41.6	37.6	33.6	56	51.4	46.8	42.2	37.6	33
2070	60	60	58.3	53.1	48	42.9	70	64.5	59	53.5	48	42.5
2082	75	75	72.9	66.4	60	53.6	82	79.3	72.9	66.4	60	53.6

1. Applicable Motor Control Methods: GA500 Parameter A1-02 = 6
2. Refer to the GA500 Technical Manual for AOLV/PM Carrier Frequency Derating information.

Table 63: 480 V, Three-Phase, Carrier Frequency Derating

Catalog Code GA50U..	Carrier Frequency Derating ^{1 2}											
	Heavy Duty Rating Amps						Normal Duty Rating Amps					
	2 kHz	5 kHz	8 kHz	10 kHz	12.5 kHz	15 kHz	2 kHz	5 kHz	8 kHz	10 kHz	12.5 kHz	15 kHz
4001	1.2	1.2	1.2	1.1	0.9	0.7	1.2	1.2	1.2	1.1	0.9	0.7
4002	1.8	1.8	1.8	1.6	1.3	1.1	2.1	2.1	1.8	1.6	1.3	1.1
4004	3.4	3.4	3.4	3	2.5	2	4.1	4	3.4	3	2.5	2
4005	4.8	4.8	4.8	4.3	3.6	2.9	5.4	5.4	4.8	4.2	3.6	2.9
4007	5.5	5.5	5.5	4.9	4.1	3.3	7.1	6.5	5.5	4.9	4.1	3.3
4009	7.3	7.3	7.3	6.5	5.4	4.4	8.9	8.6	7.3	6.5	5.4	4.4
4012	9.2	9.2	9.2	8.1	6.8	5.5	11.9	10.8	9.2	8.2	6.8	5.5
4018	14.8	14.8	14.8	13.1	11	8.9	17.8	17.3	14.7	13.1	11	8.8
4023	18	18	18	13.1	11	11	23.4	21.3	18.2	16.1	13.4	11
4031	24	24	24	21.3	17.8	14	31	28.2	24.1	21.3	17.9	14
4038	31	31	31	27.5	23	19	38	36.3	31	27.5	23	19
4044	39	39	39	34.5	29	23	44	44	39	34.5	29	23
4060	45	45	45	39.9	33.4	27	60	54.5	46.3	40.8	33.9	27

1. Applicable Motor Control Methods: GA500 Parameter A1-02 = 0, 2, 5, 8.
2. Refer to the GA500 Technical Manual for AOLV/PM Carrier Frequency Derating information.

Table 64: 480 V, Three-Phase, Carrier Frequency Derating (Permanent Magnet (PM) Control)

Catalog Code GA50U..	Carrier Frequency Derating ^{1 2}											
	Heavy Duty Rating Amps						Normal Duty Rating Amps					
	2 kHz	5 kHz	8 kHz	10 kHz	12.5 kHz	15 kHz	2 kHz	5 kHz	8 kHz	10 kHz	12.5 kHz	15 kHz
4001	1.2	1.2	1.1	0.9	0.7	0.5	1.2	1.2	1.1	0.9	0.7	0.5
4002	1.8	1.8	1.7	1.4	1.1	0.8	2.1	2	1.7	1.4	1.1	0.8
4004	3.4	3.4	3.2	2.6	2	1.5	4.1	3.8	3.2	2.6	2	1.5
4005	4.8	4.8	4.5	3.7	2.9	2.1	5.4	5.3	4.5	3.7	2.9	2.1
4007	5.5	5.5	5.2	4.2	3.3	2.4	7.1	6.2	5.2	4.3	3.3	2.4
4009	7.3	7.3	6.9	5.6	4.4	3.1	8.9	8.1	6.9	5.6	4.4	3.1
4012	9.2	9.2	8.7	7.1	5.5	3.9	11.9	10.3	8.7	7.1	5.5	3.9
4018	14.8	14.8	14	11.4	8.9	6.3	17.8	16.4	15.2	11.4	8.8	6.3
4023	18	18	17	13.9	10.8	7.7	23.4	20.3	17.1	14	10.8	7.7
4031	24	24	22.6	18.5	14.4	10.3	31	26.9	22.7	18.6	14.4	10.3
4038	31	31	29.2	23.9	18.6	13.3	38	34.5	29.2	23.9	18.6	13.3
4044	39	39	36.8	30.1	23.4	16.7	44	43.5	36.8	30.1	23.4	16.7
4060	45	45	42.4	34.7	27	19.3	60	51.8	43.5	35.3	27	18.8

1. Applicable Motor Control Methods: GA500 Parameter A1-02 = 6.
2. Refer to the GA500 Technical Manual for AOLV/PM Carrier Frequency Derating information.

Altitude

Install the drive in a location that with an altitude of 1000 m (3281 ft) or lower. Derate the output current by 1% for each 100 m (328 ft) to install the drive in altitudes between 1000 m to 3000 m (3281 ft to 9843 ft). It is not necessary to derate the rated voltage in these conditions:

- Installing the drive at 2000 m (6562 ft) or lower.
- Installing the drive between 2000 m to 4000 m (6562 ft to 13132 ft) and grounding the neutral point on the power supply.

Contact Yaskawa or your nearest sales representative when the drive is not grounded with the neutral network.

Ambient Temperature

IP20/Protected Chassis: -10 °C to + 50 °C (14 °F to 122 °F)

IP20/UL Type 1: -10 °C to + 40 °C (14 °F to 104 °F)

- Drive reliability is better in environments that do not have wide temperature fluctuations.
- When installing the drive in an enclosure, use a cooling fan or air conditioner to keep the internal air temperature in the permitted range.
- Do not let the drive freeze.
- To install the drive in areas with ambient temperatures between 40 °C to 60 °C (104 °F to 140 °F), see Figure 11 for output current derating.

Figure 12: Ambient Temperature Derating Chart

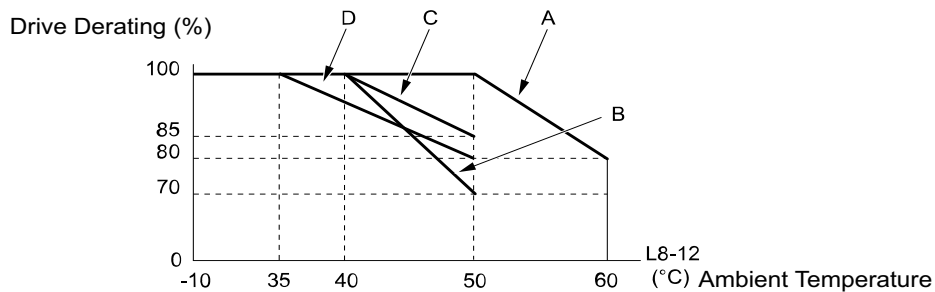

A - L8-35 = 0 [IP20, Finless]

C - L8-35 = 2 [UL Type 1, Wall Mount]

B - L8-35 = 1 [Side-by-Side Installation]

D - L8-35 = 3 [External Heatsink]

Watt Loss

Watt Loss without EMC Filter

Table 65: 240 V, Single-Phase Drives

Catalog Code GA50U...	240 V Normal Duty					240 V Heavy Duty (Fc = 2 kHz)					240 V Heavy Duty (Fc = Default)				
	Rated Output Current	Carrier Frequency	Interior Unit Loss	Cooling Fin Loss	Total Loss	Rated Output Current	Carrier Frequency	Interior Unit Loss	Cooling Fin Loss	Total Loss	Rated Output Current	Carrier Frequency	Interior Unit Loss	Cooling Fin Loss	Total Loss
	A	kHz	W	W	W	A	kHz	W	W	W	A	kHz	W	W	W
B001	1.2	2	8	6	14	0.8	2	7	4	11	0.8	10	8	5	13
B002	1.9	2	14	11	25	1.6	2	10	7	17	1.6	10	10	9	19
B004	3.5	2	14	17	31	3	2	13	13	26	3	10	14	16	30
B006	6	2	17	26	43	5	2	17	23	40	5	10	18	28	46
B010	9.6	2	36	50	86	8	2	30	37	67	8	8	31	42	73
B012	12.2	2	48	60	108	11	2	40	48	88	11	8	41	55	96
B018	--	2	49	92	141	17.6	2	49	72	121	17.6	8	53	98	151

Table 66: 240 V, Three-Phase Drives

Catalog Code GA50U...	240 V Normal Duty					240 V Heavy Duty (Fc = 2 kHz)					240 V Heavy Duty (Fc = Default)				
	Rated Output Current	Carrier Frequency	Interior Unit Loss	Cooling Fin Loss	Total Loss	Rated Output Current	Carrier Frequency	Interior Unit Loss	Cooling Fin Loss	Total Loss	Rated Output Current	Carrier Frequency	Interior Unit Loss	Cooling Fin Loss	Total Loss
	A	kHz	W	W	W	A	kHz	W	W	W	A	kHz	W	W	W
2001	1.2	2	7	5	12	0.8	2	6	4	10	0.8	10	6	5	11
2002	1.9	2	9	9	18	1.6	2	7	7	14	1.6	10	7	8	15
2004	3.5	2	11	16	27	3	2	9	13	22	3	10	10	16	26
2006	6	2	14	25	39	5	2	13	22	35	5	10	14	27	41
2010	9.6	2	25	51	76	8	2	17	37	54	8	8	18	43	61
2012	12.2	2	30	61	91	11	2	23	49	72	11	8	24	56	80
2021	21	2	52	111	163	17.6	2	36	83	119	17.6	8	40	108	148
2030	30	2	63	240	303	25	2	45	163	208	25	8	49	187	236
2042	42	2	84	307	391	33	2	55	200	255	33	8	60	232	292
2056	56	2	109	367	476	47	2	77	269	346	47	8	85	318	403
2070	70	2	142	534	676	60	2	108	411	519	60	8	119	473	592
2082	82	2	160	531	691	75	2	132	439	571	75	8	148	525	673

Table 67: 480 V, Three-Phase Drives

Catalog Code GA50U...	480 V Normal Duty					480 V Heavy Duty (Fc = 2 kHz)					480 V Heavy Duty (Fc = Default)				
	Rated Output Current	Carrier Frequency	Interior Unit Loss	Cooling Fin Loss	Total Loss	Rated Output Current	Carrier Frequency	Interior Unit Loss	Cooling Fin Loss	Total Loss	Rated Output Current	Carrier Frequency	Interior Unit Loss	Cooling Fin Loss	Total Loss
	A	kHz	W	W	W	A	kHz	W	W	W	A	kHz	W	W	W
4001	1.2	2	8	7	15	1.2	2	8	7	15	1.2	8	9	11	20
4002	2.1	2	13	12	25	1.8	2	10	10	20	1.8	8	11	16	27
4004	4.1	2	14	24	38	3.4	2	13	21	34	3.4	8	15	31	46
4005	5.4	2	16	32	48	4.8	2	15	29	44	4.8	8	18	42	60
4007	7.1	2	20	44	64	5.6	2	16	33	49	5.6	8	18	49	67
4009	8.9	2	28	58	86	7.3	2	21	45	66	7.3	8	25	65	90
4012	11.9	2	39	83	122	9.2	2	27	60	87	9.2	8	32	85	117
4018	17.5	2	52	155	207	14.8	2	48	126	174	14.8	8	55	166	221
4023	23.4	2	86	236	322	18	2	53	152	205	18	8	61	200	261
4031	31	2	101	284	385	24	2	68	191	259	24	8	79	255	334
4038	38	2	108	341	449	31	2	81	256	337	31	8	95	338	433
4044	44	2	137	417	554	39	2	109	338	447	39	8	127	442	569
4060	60	2	176	490	666	45	2	114	328	442	45	8	135	446	581

Note: Refer to the GA500 Drive Technical Manual (SIEPC7106175A) for detailed Carrier Frequency Watt Loss information.

Watt Loss with EMC Filter

Table 68: 240 V, Single-Phase Drives

Catalog Code GA50U...	240 V Normal Duty					240 V Heavy Duty (Fc = 2 kHz)					240 V Heavy Duty (Fc = Default)				
	Rated Output Current	Carrier Frequency	Interior Unit Loss	Cooling Fin Loss	Total Loss	Rated Output Current	Carrier Frequency	Interior Unit Loss	Cooling Fin Loss	Total Loss	Rated Output Current	Carrier Frequency	Interior Unit Loss	Cooling Fin Loss	Total Loss
	A	kHz	W	W	W	A	kHz	W	W	W	A	kHz	W	W	W
B001E	1.2	2	9	6	15	0.8	2	8	4	12	0.8	10	9	5	14
B002E	1.9	2	18	11	29	1.6	2	12	7	19	1.6	10	12	9	21
B004E	3.5	2	19	17	36	3	2	17	13	30	3	10	18	16	34
B006E	6	2	20	26	46	5	2	20	23	43	5	10	21	28	49
B010E	9.6	2	44	50	94	8	2	34	37	71	8	8	35	42	77
B012E	12.2	2	56	60	116	11	2	45	48	93	11	8	46	55	101
B018E	N/A	2	50	92	142	17.6	2	50	72	122	17.6	8	54	98	152

Table 69: 240 V, Three-Phase Drives

Catalog Code GA50U...	240 V Normal Duty					240 V Heavy Duty (Fc = 2 kHz)					240 V Heavy Duty (Fc = Default)				
	Rated Output Current	Carrier Frequency	Interior Unit Loss	Cooling Fin Loss	Total Loss	Rated Output Current	Carrier Frequency	Interior Unit Loss	Cooling Fin Loss	Total Loss	Rated Output Current	Carrier Frequency	Interior Unit Loss	Cooling Fin Loss	Total Loss
	A	kHz	W	W	W	A	kHz	W	W	W	A	kHz	W	W	W
2001E	1.2	2	8	5	13	0.8	2	7	4	11	1.2	10	7	5	12
2002E	1.9	2	12	9	21	1.6	2	8	7	15	1.9	10	8	8	16
2004E	3.5	2	15	16	31	3	2	12	13	25	3.5	10	13	16	29
2006E	6	2	21	25	46	5	2	20	22	42	6	10	21	27	48
2010E	9.6	2	26	51	77	8	2	18	37	55	9.6	8	19	43	62
2012E	12.2	2	31	61	92	11	2	24	49	73	12.2	8	25	56	81
2021E	21	2	53	111	164	17.6	2	37	83	120	21	8	41	108	149
2030E	30	2	64	240	304	25	2	46	163	209	30	8	50	187	237
2042E	42	2	85	307	392	33	2	56	200	256	42	8	61	232	293
2056E	56	2	110	367	477	47	2	78	269	347	56	8	86	318	404
2070E	70	2	143	534	677	60	2	109	411	520	70	8	120	473	593
2082E	82	2	161	531	692	75	2	133	439	572	82	8	149	525	674

Table 70: 480 V, Three-Phase Drives

Catalog Code GA50U...	480 V Normal Duty					480 V Heavy Duty (Fc = 2 kHz)					480 V Heavy Duty (Fc = Default)				
	Rated Output Current	Carrier Frequency	Interior Unit Loss	Cooling Fin Loss	Total Loss	Rated Output Current	Carrier Frequency	Interior Unit Loss	Cooling Fin Loss	Total Loss	Rated Output Current	Carrier Frequency	Interior Unit Loss	Cooling Fin Loss	Total Loss
	A	kHz	W	W	W	A	kHz	W	W	W	A	kHz	W	W	W
4001E	1.2	2	9	7	16	1.2	2	9	7	16	1.2	8	10	11	21
4002E	2.1	2	14	12	26	1.8	2	11	10	21	1.8	8	12	16	28
4004E	4.1	2	16	24	40	3.4	2	15	21	36	3.4	8	17	31	48
4005E	5.4	2	18	32	50	4.8	2	17	29	46	4.8	8	20	42	62
4007E	7.1	2	23	44	67	5.6	2	18	33	51	5.6	8	20	49	69
4009E	8.9	2	33	58	91	7.3	2	24	45	69	7.3	8	28	65	93
4012E	11.9	2	41	83	124	9.2	2	29	60	89	9.2	8	34	85	119
4018E	17.5	2	56	155	211	14.8	2	52	126	178	14.8	8	59	166	225
4023E	23.4	2	94	236	330	18	2	57	152	209	18	8	65	200	265
4031E	31	2	109	284	393	24	2	73	191	264	24	8	84	255	339
4038E	38	2	119	341	460	31	2	89	256	345	31	8	103	338	441
4044E	44	2	151	417	568	39	2	119	338	457	39	8	137	442	579
4060E	60	2	200	490	690	45	2	128	328	456	45	8	149	446	595

Note: Refer to the GA500 Drive Technical Manual (SIEPC71061752A) for detailed Carrier Frequency Watt Loss information.

Branch Circuit Protection

Table 71: 240 V AC Input Branch Circuit Protection

Alternate Branch Circuit Protection fuse selection evaluation based on UL61800-5-1.

GA500 Series	Semiconductor Fuse		Class CC, J or T Fuse ¹		Class RK Fuse ² or MCCB (Molded Case Circuit Breaker) ³					
	Busmann Part Number	Maximum SCOR (Drive-Fuse Combination)	Maximum Rating (A) ⁴	Maximum SCOR (Drive Fuse Combination)	Maximum RK Fuse Rating (A) ⁴	Maximum SCOR (Drive-Fuse Combination)	Maximum MCCB Rating (A) ⁴	Maximum SCOR (Drive-MCCB Combination)	Mfr Catalog No. (Schneider Electric)	Minimum Enclosure Volume (in ³) ⁵
B001XXX	FWH-25A14F	31kA	3.5	31kA	3.5	31kA	15	31kA	HLL36015	600
B002XXX	FWH-25A14F	31kA	6	31kA	6	31kA	15	31kA	HLL36015	600
B004XXX	FWH-60B	31kA	12	31kA	12	31kA	15	31kA	HLL36015	600
B006XXX	FWH-80B	31kA	20	31kA	20	31kA	25	31kA	HLL36025	600
B010XXX	FWH-100B	31kA	35	31kA	35	31kA	40	31kA	HLL36040	960
B012XXX	FWH-125B	31kA	40	31kA	40	31kA	45	31kA	HLL36045	960
B018XXX	FWH-150B	31kA	60	31kA	60	31kA	70	31kA	HLL36070	960
2001XXX	FWH-25A14F	31kA	2	31kA	2	31kA	15	31kA	HLL36015	600
2002XXX	FWH-25A14F	31kA	3.2	31kA	3.2	31kA	15	31kA	HLL36015	600
2004XXX	FWH-25A14F	31kA	6	31kA	6	31kA	15	31kA	HLL36015	600
2006XXX	FWH-25A14F	31kA	10	31kA	10	31kA	15	31kA	HLL36015	600
2010XXX	FWH-70B	31kA	15	31kA	15	31kA	15	31kA	HLL36015	600
2012XXX	FWH-70B	31kA	20	31kA	20	31kA	20	31kA	HLL36020	600
2021XXX	FWH-90B	31kA	35	31kA	35	31kA	40	31kA	HLL36040	960
2030XXX	FWH-100B	31kA	50	31kA	50	31kA	60	31kA	HLL36060	960
2042XXX	FWH-150B	31kA	70	31kA	n/a	n/a	80	31kA	HLL36080	960
2056XXX	FWH-200B	31kA	90	31kA	n/a	n/a	110	31kA	HLL36110	2560
2070XXX	FWH-200B	31kA	110	31kA	n/a	n/a	125	31kA	HLL36125	2560
2082XXX	FWH-225B	31kA	125	31kA	n/a	n/a	150	31kA	HLL36150	2560

1. Class T fuses are fast acting (non-time delay) only.
2. Protected enclosure required for RK fuses (same as MCCB).
3. The specified MCCB is current limiting. An equivalent listed current limiting type MCCB is able to be used where the peak let-through current and I_{2t} of the equivalent MCCB is not greater than the specified MCCB.
4. Maximum Fuse or MCCB ratings are based on ND ratings and 175 and 200% respectively.
5. Ventilated enclosure type.

Table 72: 480 V AC Input Branch Circuit Protection

Alternate Branch Circuit Protection fuse selection evaluation based on UL61800-5-1.

GA500 Series		Semiconductor Fuse		Class CC, J or T Fuse ¹		Class RK Fuse ² or MCCB (Molded Case Circuit Breaker) ³				
Catalog Code GA50X	Bussmann Part Number	Maximum SCCR (Drive-Fuse Combination)	Maximum Rating (A) ⁴	Maximum SCCR (Drive-Fuse Combination)	Maximum RK Rating (A) ⁴	Maximum SCCR (Drive-Fuse Combination)	Maximum MCCB Rating (A) ⁴	Maximum SCCR (Drive-MCCB Combination)	Mfr Catalog No. (Schneider Electric)	Minimum Enclosure Volume (in ³) ⁵
4001XXX	FWH-40B	31kA	2	31kA	2	31kA	15	31kA	HLL36015	960
4002XXX	FWH-40B	31kA	3.5	31kA	3.5	31kA	15	31kA	HLL36015	960
4004XXX	FWH-50B	31kA	7	31kA	7	31kA	15	31kA	HLL36015	960
4005XXX	FWH-70B	31kA	9	31kA	9	31kA	15	31kA	HLL36015	960
4007XXX	FWH-70B	31kA	12	31kA	12	31kA	15	31kA	HLL36015	960
4009XXX	FWH-90B	31kA	15	31kA	15	31kA	15	31kA	HLL36015	960
4012XXX	FWH-90B	31kA	20	31kA	20	31kA	20	31kA	HLL36020	960
4018XXX	FWH-80B	31kA	30	31kA	30	31kA	35	31kA	HLL36035	960
4023XXX	FWH-100B	31kA	40	31kA	40	31kA	40	31kA	HLL36040	960
4031XXX	FWH-125B	31kA	50	31kA	50	31kA	60	31kA	HLL36060	2560
4038XXX	FWH-175B	31kA	60	31kA	n/a	n/a	75	31kA	HLL36075	2560
4044XXX	FWH-200B	31kA	75	31kA	n/a	n/a	80	31kA	HLL36080	2560
4060XXX	FWH-200B	31kA	100	31kA	n/a	n/a	110	31kA	HLL36110	2560

1. Class T fuses are fast acting (non-time delay) only.
2. Protected enclosure required for RK fuses (same as MCCB).
3. The specified MCCB is current limiting. An equivalent listed current limiting type MCCB is able to be used where the peak let-through current and I2t of the equivalent MCCB is not greater than the specified MCCB.
4. Maximum Fuse or MCCB ratings are based on ND ratings and 175 and 200% respectively.
5. Ventilated enclosure type.

Table 73: DC Input Branch Circuit Protection

DC input applications are for protected chassis rated models only.

GA500 Series	Semiconductor Fuse	
Catalog Code	Bussmann Part Number	Maximum SCCR
GA50*B001	FWH-25A14F	31kA
GA50*B002	FWH-25A14F	31kA
GA50*B004	FWH-60B	31kA
GA50*B006	FWH-80B	31kA
GA50*B010	FWH-100B	31kA
GA50*B012	FWH-125B	31kA
GA50*B018	FWH-150B	31kA
GA50*2001	FWH-25A14F	31kA
GA50*2002	FWH-25A14F	31kA
GA50*2004	FWH-25A14F	31kA
GA50*2006	FWH-25A14F	31kA
GA50*2010	FWH-70B	31kA
GA50*2012	FWH-70B	31kA
GA50*2021	FWH-90B	31kA
GA50*2030	FWH-100B	31kA
GA50*2042	FWH-150B	31kA
GA50*2056	FWH-200B	31kA
GA50*2070	FWH-200B	31kA
GA50*2082	FWH-225B	31kA
GA50*4001	FWH-40B	31kA
GA50*4002	FWH-40B	31kA
GA50*4004	FWH-50B	31kA
GA50*4005	FWH-70B	31kA
GA50*4007	FWH-70B	31kA
GA50*4009	FWH-90B	31kA
GA50*4012	FWH-90B	31kA
GA50*4018	FWH-80B	31kA
GA50*4023	FWH-100B	31kA
GA50*4031	FWH-125B	31kA
GA50*4038	FWH-175B	31kA
GA50*4044	FWH-200B	31kA
GA50*4060	FWH-200B	31kA

GA500 Series

Selection Guide

YASKAWA AMERICA, INC.

2121 Norman Drive S.
Waukegan, IL 60085 USA
1-800-YASKAWA (927-5292)
WWW.YASKAWA.COM

**DRIVE CENTER
(INVERTER PLANT)**

13-1 Nishimiyaichi 2 Chome,
Yukuhashi, Fukuoka
824-8511 Japan
Tel: +81-930-23-1401
WWW.YASKAWA.CO.JP

YASKAWA EUROPE GmbH

Hauptstr. 185
65760 Eschborn, Germany
Fon: +49 (0)6196 569-500
WWW.YASKAWA.EU.COM

**YASKAWA ELÉTRICO
DO BRASIL LTDA.**

Av. Piraporinha, 777
Vila Nogueira Diadema
São Paulo, Brasil 09950-000
Pabx: +55 11 3585-1100
WWW.YASKAWA.COM.BR

In the event that the end user of this product is to be the military and said product is to be employed in any weapons systems or the manufacture thereof, the export will fall under the relevant regulations as stipulated in the Foreign Exchange and Foreign Trade Regulations. Therefore, be sure to follow all procedures and submit all relevant documentation according to any and all rules, regulations and laws that may apply. Specifications are subject to change without notice for ongoing product modifications and improvements.
© 2010-2021 YASKAWA America, Inc.

YASKAWA AMERICA, INC.

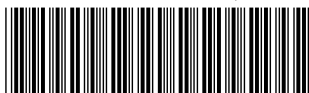

SL.GA500.01

SL.GA500.01

Revision: B-3

July 2021

Published in USA

YASKAWA